

1

2

3

4

5

6

REVISIONS

REV.	COMMENT	DATE	APPROVED
0	INITIAL RELEASE	2023-09-12	CHRIS

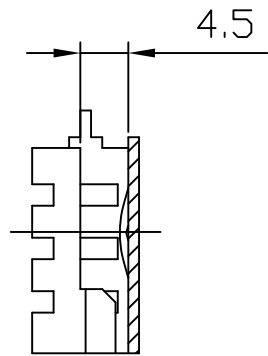
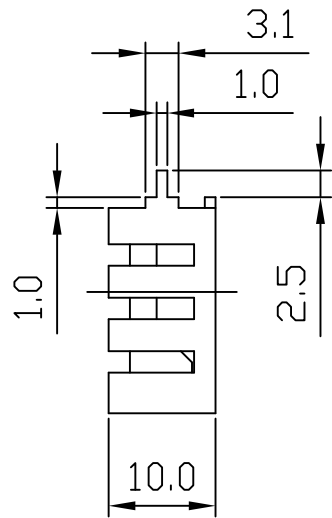
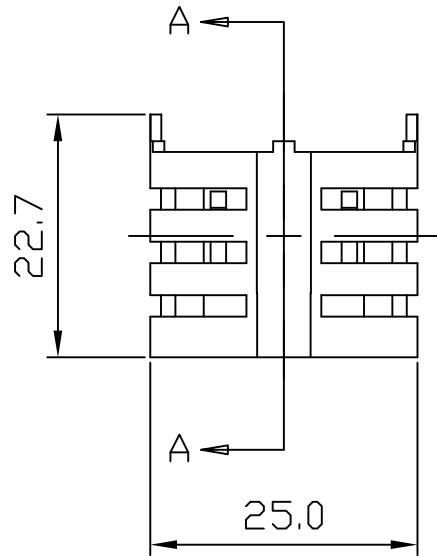
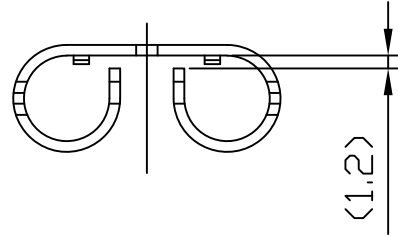

SECTION A-A

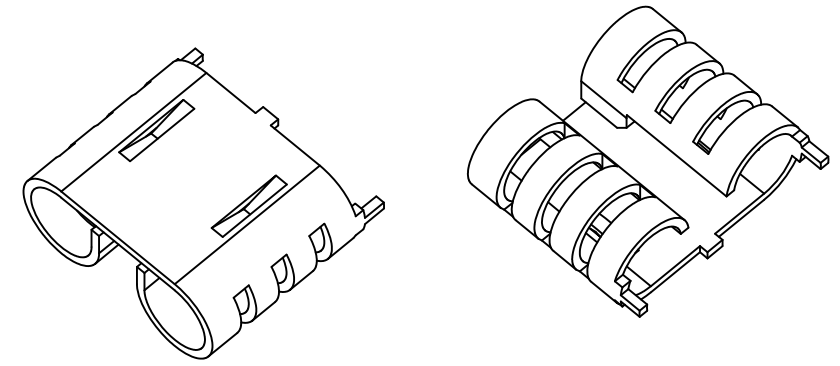

ISOMETRIC VIEW  
SCALE 1:1

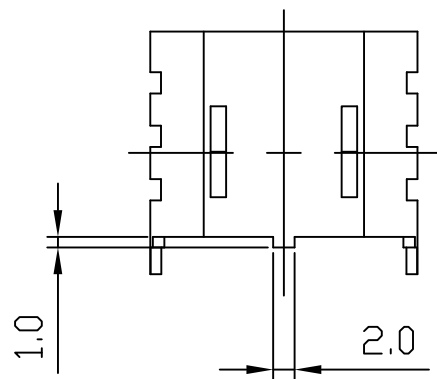
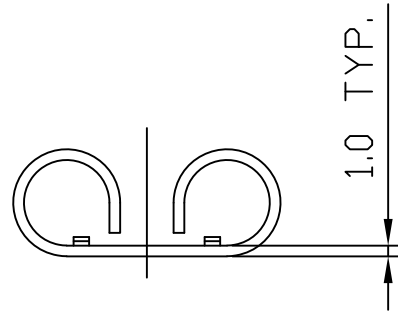

NOTES:

1. THIS DRAWING CONTAINS OVERALL DIMENSIONS ONLY. REFER TO 3D CAD DATABASE FOR COMPLETE PART INFORMATION.
2. PARTS TO BE CLEAN AND FREE OF CRACKS, FOREIGN MATTER. NO OIL OR LUBRICANTS ON THE SURFACE.
3. ALL DIMENSIONS SHOWN SHALL BE CHECKED AT FIRST ARTICLE INSPECTION.
4. REMOVE ALL BURRS AND SHARP EDGES.
5. FINISHED PRODUCT TO BE RoHS COMPLIANT.
6. TOLERANCE: ±0.50mm

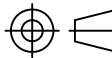
DIMENSIONAL TOLERANCE			DRAWN	TITLE				
DECIMAL PLACES	MILLIMETERS	INCHES						
.	-	-	SIDNEY	STAMPED HEAT SINK				
.X	-	-		MATERIAL AL 1050				
.XX	-	-	CHECKED	FINISH CLEAN				
UNLESS OTHERWISE SPECIFIED			CHRIS	CUS. PART NO.		CUS. REV.		
ANGULAR DIMENSIONS ± 1.0°		THIRD ANGLE PROJECTION 		APPROVED		PART NO. JBHAS0083		REV. 0
SCALE 1:1	UNIT mm	SIZE A4	CHRIS	SHEET 1 OF 1		DATE 2023-09-12		

1

2

3

4

5

6