

1

2

3

4

5

6

REVISIONS

REV.	COMMENT	DATE	APPROVED
0	INITIAL RELEASE	2023-09-12	CHRIS

M3x0.5 THRU.

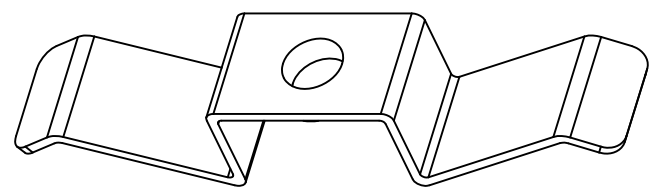
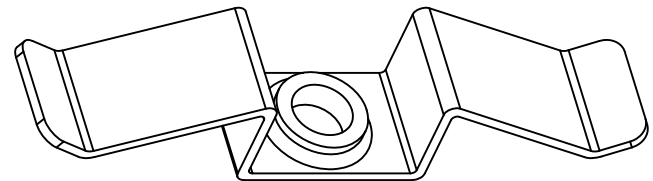
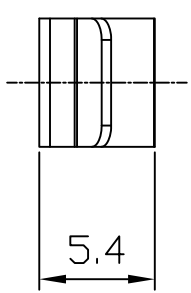
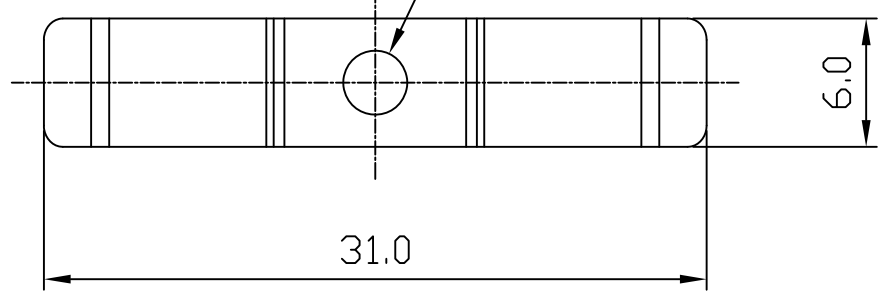

ISOMETRIC VIEW  
SCALE 2:1

D

D

C

C

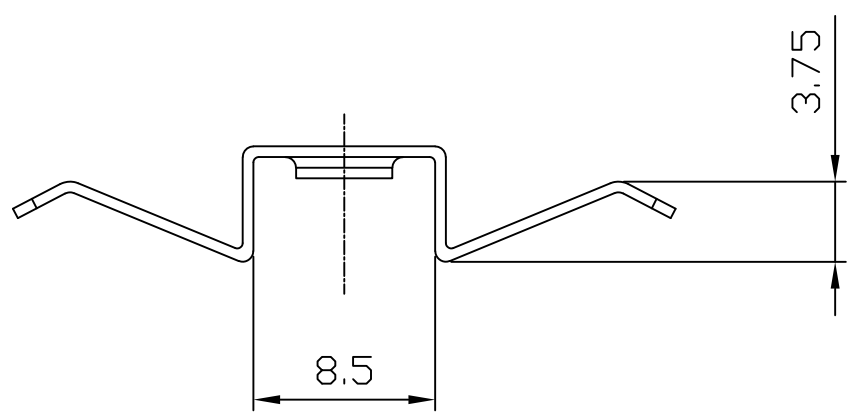

B

B

NOTES:

- THIS DRAWING CONTAINS OVERALL DIMENSIONS ONLY. REFER TO 3D CAD DATABASE FOR COMPLETE PART INFORMATION.
- PARTS TO BE CLEAN AND FREE OF CRACKS, FOREIGN MATTER. NO OIL OR LUBRICANTS ON THE SURFACE.
- ALL DIMENSIONS SHOWN SHALL BE CHECKED AT FIRST ARTICLE INSPECTION.
- REMOVE ALL BURRS AND SHARP EDGES.
- FINISHED PRODUCT TO BE RoHS COMPLIANT.
- TOLERANCE: ±0.50mm

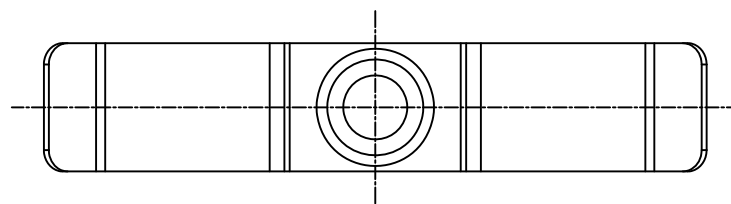

A

A

DIMENSIONAL TOLERANCE			DRAWN  SIDNEY	TITLE  CLIP			
DECIMAL PLACES	MILLIMETERS	INCHES		MATERIAL  SK7			
.	-	-		FINISH  NICKEL PLATING			
.X	-	-		CUS. PART NO.			
.XX	-	-	CHECKED  CHRIS	CUS. REV.			
UNLESS OTHERWISE SPECIFIED			APPROVED  CHRIS	PART NO.	REV.	SHEET	DATE
ANGULAR DIMENSIONS ± 1.0°		THIRD ANGLE PROJECTION		JBABS4741	0	1 OF 1	2023-09-12
SCALE	UNIT	SIZE					
2:1	mm	A4					

1

2

3

4

5

6