

1

2

3

4

5

6

REVISIONS

REV.	COMMENT	DATE	APPROVED
0	INITIAL RELEASE	2023-09-12	CHRIS

D

D

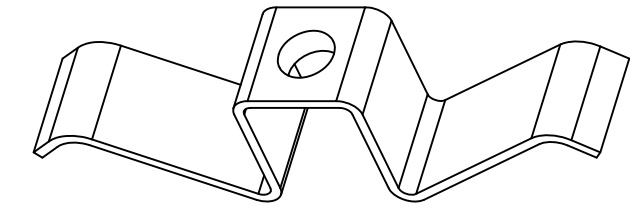
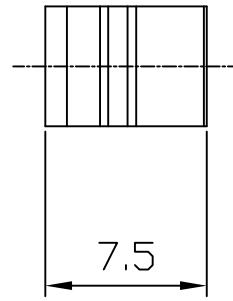
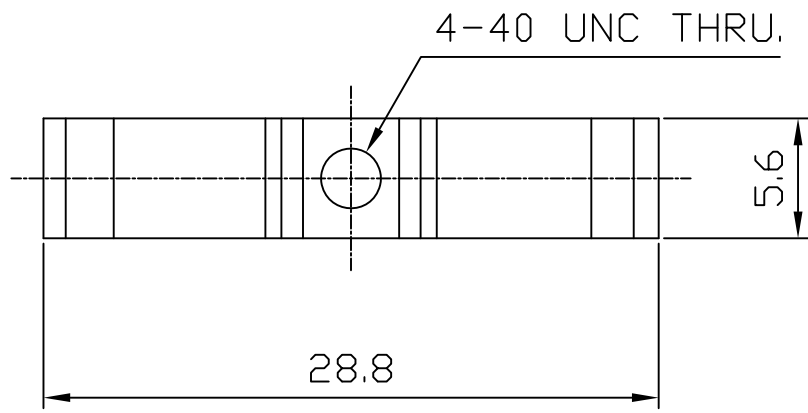

C

C

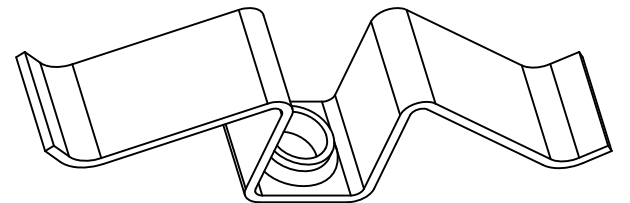
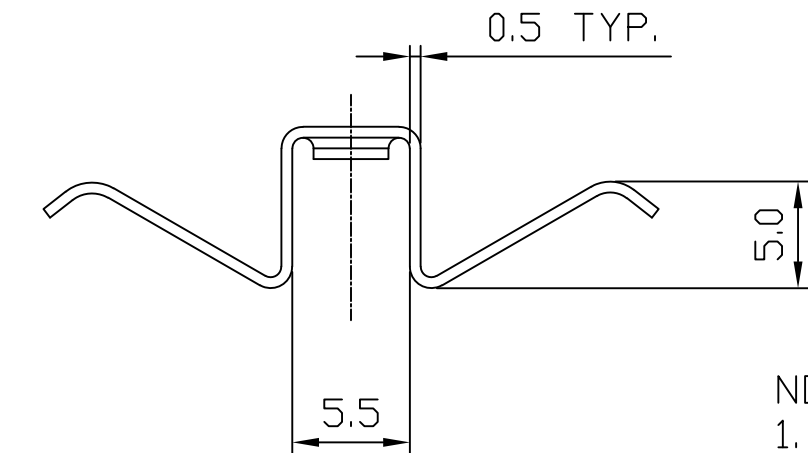

ISOMETRIC VIEW
SCALE 2:1

B

B

NOTES:

1. THIS DRAWING CONTAINS OVERALL DIMENSIONS ONLY. REFER TO 3D CAD DATABASE FOR COMPLETE PART INFORMATION.
2. PARTS TO BE CLEAN AND FREE OF CRACKS, FOREIGN MATTER. NO OIL OR LUBRICANTS ON THE SURFACE.
3. ALL DIMENSIONS SHOWN SHALL BE CHECKED AT FIRST ARTICLE INSPECTION.
4. REMOVE ALL BURRS AND SHARP EDGES.
5. FINISHED PRODUCT TO BE RoHS COMPLIANT.
6. TOLERANCE: ±0.50mm

A

A

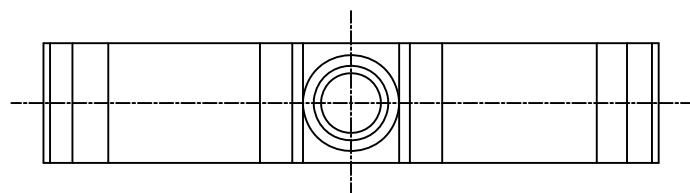

DIMENSIONAL TOLERANCE			DRAWN	TITLE	CLIP		
DECIMAL PLACES	MILLIMETERS	INCHES			MATERIAL	CRS	
.	-	-	SIDNEY	ZINC PLATING	CUS. PART NO.	CUS. REV.	
.X	-	-					
.XX	-	-	CHECKED				
UNLESS OTHERWISE SPECIFIED			CHRIS				
ANGULAR DIMENSIONS		THIRD ANGLE PROJECTION		APPROVED			
± 1.0°							
SCALE	UNIT	SIZE	CHRIS	PART NO.	REV.	SHEET	DATE
2:1	mm	A4		JBABS4682	0	1 OF 1	2023-09-12



1

2

3

4

5

6