



JARO THERMAL

SPECIFICATION FOR APPROVAL

Customer :
Customer Part No. :
Description : DC FAN
JARO Model No. : JHD0402812VBBA01(30000) REV.0
Sample Issue No. :
Sample Issue Date :
 Preliminary Specification
 Formal Specification

| | | | |
|---------------|--------------|--------|------------|
| PREPARED BY : | Franco Huang | DATE : | 08/11/2022 |
| CHECKED BY : | Ivan Chen | DATE : | 08/11/2022 |
| APPROVED BY : | Jay Su | DATE : | 08/11/2022 |

PLEASE SEND ONE COPY OF THIS SPECIFICATION BACK AFTER YOU SIGNED APPROVAL FOR PRODUCTION PRE-ARRANGEMENT.

By: _____ (printed)

Signature: _____

Date: _____



Jaro Thermal USA office
6600 Park of Commerce Blvd.
Boca Raton, Florida 33487
www.jarothermal.com
Ph: 561-241-6700
Fx: 561-241-3328

Jaro Thermal Taiwan office
Building H, No.119-1, Zhudong Rd., Renwu
Dist., Kaohsiung City, Taiwan 81448
www.jarothermal.com
Ph: +886-7-375-2053
Fx: +886-7-374-7403

We keep the world cool™



| | |
|-------------------------|--|
| JARO SPEC NUMBER | |
| | |

Revision of Spec History

| Revision | Change Content | Change page | DATE | BY |
|----------|----------------|-------------|------------|--------------|
| 0 | Created SPEC | | 08/11/2022 | Franco Huang |
| | | | | |
| | | | | |
| | | | | |
| | | | | |

Notice:

1. This specification will be changed base on Jaro Thermal 's notification. Pls refer to update revision of spec by contacting Jaro Thermal.
2. This specification clarify all the mechanical & electrical characteristics of DC brushless fans & AC brushless fans & Heatsink.
3. The specification of this product is described in detailed document. Pls do not use the fan without proper usage. Pls contact Jaro Thermal if you have special requirement which is not listed on this specification.
4. Any of change, pls contact Jaro Thermal to change the new revision in order to make sure all technical data is up to date. Any ECN change will be followed by sending new update spec.



SPECIFICATION



Jaro Model : JHD0402812VBBA01(30000)

Samples attached : pcs

Safety Approval : CE

FEATURES

| | | |
|---|--|--|
| <input checked="" type="checkbox"/> FG SIGNAL | <input type="checkbox"/> HIGH TEMP RATED | <input type="checkbox"/> IP-55 RATED |
| <input type="checkbox"/> RD SIGNAL | <input checked="" type="checkbox"/> SINGLE PHASE | <input checked="" type="checkbox"/> 4-POLE |
| <input checked="" type="checkbox"/> PWM | <input type="checkbox"/> THREE PHASE | <input type="checkbox"/> 8-POLE |

| | | | |
|--------------------------------|---|--------------------------------|---|
| DIMENSIONS | : | 40 X 40 X 28 | mm |
| BEARING TYPE | : | TWO BALL BEARINGS | |
| MOTOR PROTECTION | : | BY | IC |
| RATED VOLTAGE | : | 12.0 | VDC |
| OPERATING VOLTAGE RANGE | : | 7.0 ~ 13.2 VDC | |
| START-UP VOLTAGE | : | 7.0 | VDC , (POWER ON/OFF) |
| REAL CURRENT | : | 1.95 | Amp |
| REAL POWER | : | 23.40 | Watt |
| RATED CURRENT | : | 3.00 | Amp +10% MAX (Duty cycle 100%) |
| RATED POWER | : | 36.00 | Watt (Duty cycle 100%) |
| RATED SPEED | : | 30000 | RPM ± 10 % (Duty cycle 100%) |
| | | (IN FREE AIR AT RATED VOLTAGE) | |
| AIR FLOW | : | 35.02 | CFM (min.: 31.518 CFM) |
| AIR FLOW | : | 0.991 | CMM (min.: 0.891 CMM) |
| | | (IN FREE AIR AT RATED VOLTAGE) | |
| STATIC AIR PRESSURE | : | 5.888 | InH ₂ O (min.: 4.769 InH ₂ O) |
| STATIC AIR PRESSURE | : | 149.57 | mmH ₂ O (min.: 121.151 mmH ₂ O) |
| | | (IN FREE AIR AT RATED VOLTAGE) | |
| NOISE LEVEL | : | 66.0 | dB(A) (MAX.: 70.0 dB(A)) |
| LIFE EXPECTANCY | : | 70000 | Hours at 40°C / 65% RH |
| NET WEIGHT | : | 49 | Gram |



The standard of Jaro Thermal's fan relative humidity is 65%, and the temperature is 25°C for the standard testing. If you have any question, pls refer to environmental condition on 5-0 first. Other special request pls contact Jaro Thermal for spec checking.



SPECIFICATION

JARO MODEL: JHD0402812VBBA01(30000)

1-0 MATERIAL

- 1-1 Frame Material - PBT OF UL 94V-0
- 1-2 Fan Blade Material - PBT OF UL 94V-0
- 1-3 Other material – See 8.0 Dimension Drawing
- 1-4 Environmental Standard
 - [V] RoHS
 - [V] REACH
 - [] Halogen Free

2-0 FAN VOLTAGE CURRENT, LOCK ROTOR, AIR FLOW, STATIC PRESSURE & NOISE DEFINITION

- 2-1 Start Voltage - By sudden switching ON fan is start to rotate.
- 2-2 Input Power - Input Power shall be measured after 3 minutes for continuing rotation by rated voltage.
- 2-3 Rated Current - Rated Current shall be measured after 3 minutes by continuing rotation by rated voltage.
- 2-4 Rated Speed - Rated Speed shall be measured after 3 minutes for continuing rotation by rated voltage.
- 2-5 Locked Rotor Current : Locked current shall be measured within one minute of rotor locked, after 3 minutes by continuing rotation at rated voltage in clean air.
- 2-6 Air Flow & Static Pressure : The air flow data and static pressures should be determined in accordance with AMCA-210 standard or DIN24163 specification in chamber testing and record the test record.
- 2-7 Noise Level : The measurement of noise level is carried out with reference to CNS8753 in an anechoic chamber with the microphone positioned 1 meter from the air intake. Testing fan shall be hung in clean air .

Noise Level Measure

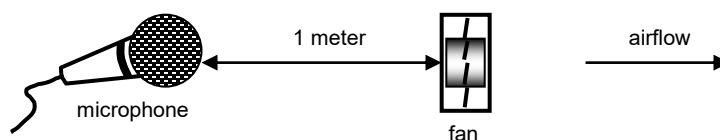



SPECIFICATION

JARO MODEL: JHD0402812VBBA01(30000)

3-0 FAN FUNCTION DEFINITION

- 3-1 Rotation Direction - Counterclockwise from impeller side.
- 3-2 Lock Rotor Condition
No damage for winding or electronic in locked rotor condition. And no damage after 72hrs continuing for lock rotor condition.
- 3-3 Auto Restart
Fan will automatic restart without any abnormal usage.
- 3-4 Dead Angle
Switch the fan change from off to on condition. Restart the fan, it will automatic restart by fan power on.
- 3-5 Polarity
Check the voltage and polarity before turn on the power to the fan.
- 3-6 Insulation Resistance
Do not use < 10M ohm between housing and positive end of lead wire (red) at 500V DC.
- 3-7 Dielectric Strength
No damage should be found at 500 VAC for 60 seconds, measured with 1mA trip current between housing and positive end of lead wire.

4-0 FAN PACKAGE TEST

- 4-1 Free Drop Shock
Base on Jaro Thermal's standard package, the fan package will test and drops on any three faces - Test standard is 30cm height. The base is wood board for 10mm thick.

5-0 FAN ENVIRONMENTAL CONDITION

- 5-1 Operating Temperature / Humidity
-10°C to +70°C at humidity 5 to 90% Relative humidity.
- 5-2 Humidity
After 96 hours, 95% RH, 40+/-2°C per MIL-STD-202F, method 103B humidity test, the measured data on insulation resistance and dielectric strength shall meet the specification.
- 5-3 Storage Temperature
All function shall be normal after 500 hours storage at -40°C to +75 °C with a 24 hour recovery period at room temperature. Humidity 5% to 95% Relative humidity.
- 5-4 Do not store this fan in an environment with high humidity. This fan must be stored in accordance with the storage temperature. Do not store the fan for over 6 months; If this fan is stored for more than 6 months, JARO THERMAL recommends functional testing before using.



SPECIFICATION

JARO MODEL: JHD0402812VBBA01(30000)

5-5 Improper way to disassembled fan will cause the fan get into dust or dip into water. Which will in defects is not covered in the warranty. Do not use the fan in the environment with corrosive air or liquid.

6-0 MASS PRODUCTION SAMPLE PLAN INSPECTION

All fans shall meet the quality inspection under MIL-STD-105E standard list as follow:

Critical 0.25%

Major 1.00%

Minor 2.50%

7-0 FAN USE WITH CAUTION

7-1 Please do not stick a grease and/or an oil to the fan housing or blade which may have a harmful influence by a chemical reaction at high humidity.

7-2 If the fan is reinstalled, please pay special attention to the noise due to the vibration (or resonance).

7-3 During the testing of the fan, please make sure the finger guard is use for your safety.

7-4 While the fan is running, please do not lock the fan intentionally for a long time. This will cause overheating by long period locking status. This action will damage the fan.

7-5 Please do not touch and push Fan Blade with fingers or others, fan blade and ball bearings may be damaged and it causes noise defect.

7-6 Do not carry the fan by its lead wires.

7-7 If the fan does not have the polarity protection function, the connection of the colored wires should be red + red, and black + black, or else the fan will be damaged in no time.

7-8 For the models without reverse connection of polarity protection, please do not connect the lead wire in reverse position.

7-9 Please don't install this fan in series with 2x voltage inputs. For example, if a single fan rated at 12V, then don't install two of them in series with 24V input.

7-10 Every specific fan is designed for its certain application (project). Therefore, if you want to use this fan in other application (project), please inform JARO first so that we can confirm whether there is any issue which might be incurred from the reason of this different application (project) or not.

7-11 The "Life Expectancy" of this fan has not been evaluated for use in combination with any end application. Therefore, the Life Expectancy in the Test Reports(L10 and MTTF Report) that relate to this fan is for reference only and shall not construe any kind of warranty of JARO to the life of any specific fan , either expressed or implied.

7-12 The period of product warranty , unless otherwise agreed by JARO in written , shall be 12 months staring from the date of production.



DIMENSION DRAWING

JARO MODEL: JHD0402812VBBA01(30000)

8-0 DIMENSIONS

All dimensions, Direction of rotation and air flow were specified as per drawing attached.

Description: DC Fan with:

Lead Wire: UL10368 , AWG#26 , 300 ± 10 mm lead length.

RED WIRE----- (+)

BLACK WIRE----- (-)

YELLOW WIRE----- (FG)

BLUE WIRE----- (PWM)

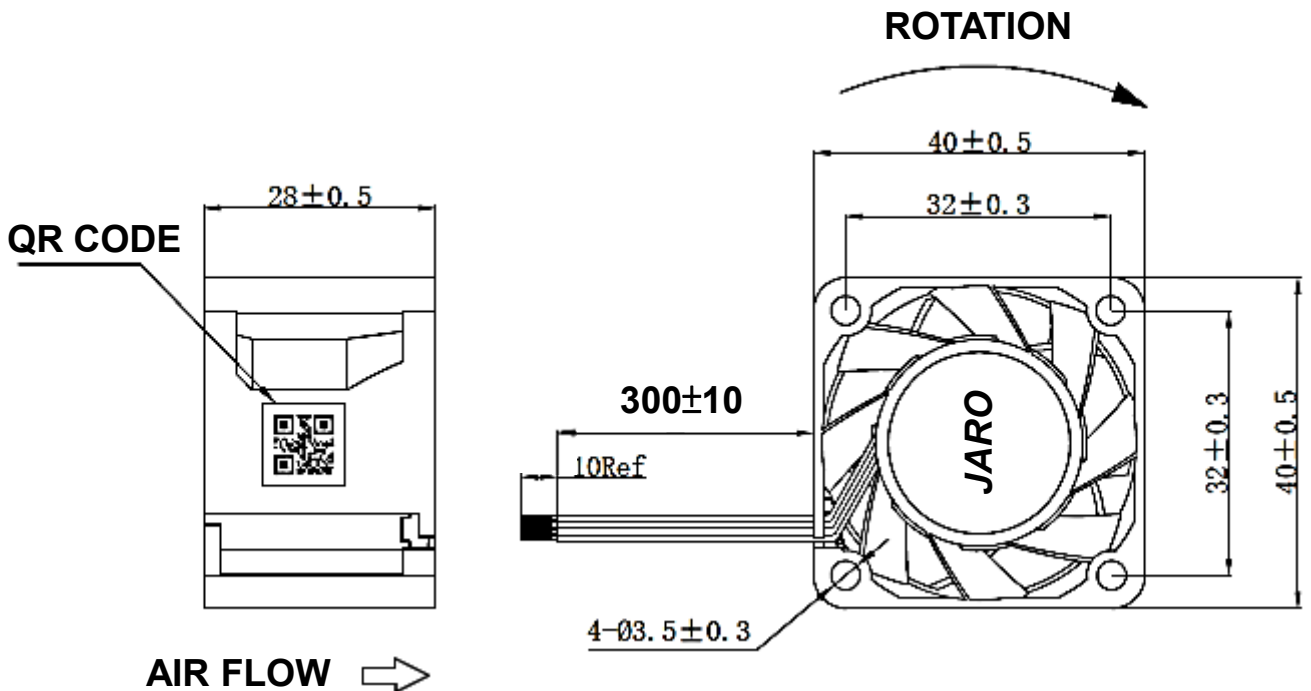

DIAGRAM OF DIMENSIONS: Dimensions in millimeters
NOT TO SCALE. ALL COMPONENTS MUST BE RoHS/REACH COMPLIANT.

Drawing Note: N/A

Safety : CE



JARO LABEL DRAWING

JARO MODEL: JHD0402812VBBA01(30000)

Label Drawing

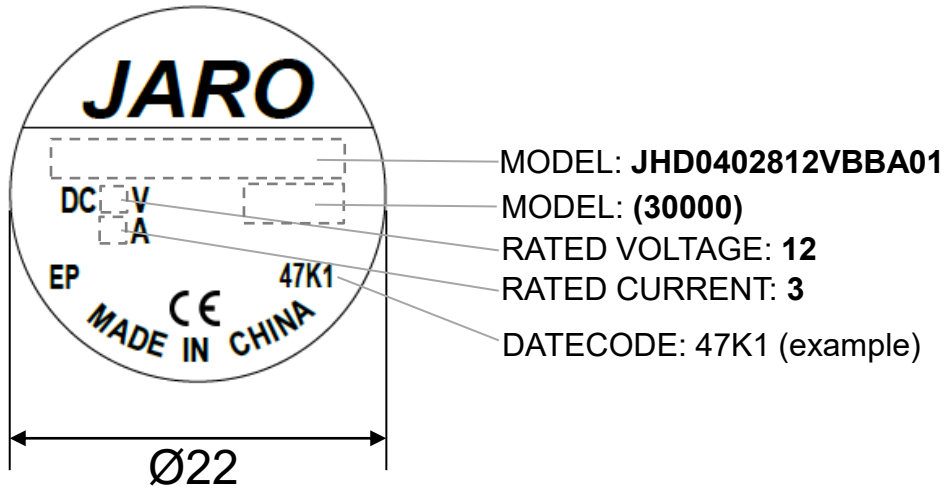

| Label Material | Dimension | Background color |
|----------------|-----------|------------------|
| PET | Ø=22mm | Silver |



PERFORMANCE CURVE

JARO MODEL: JHD0402812VBBA01(30000)

9-0 PERFORMANCE CURVE

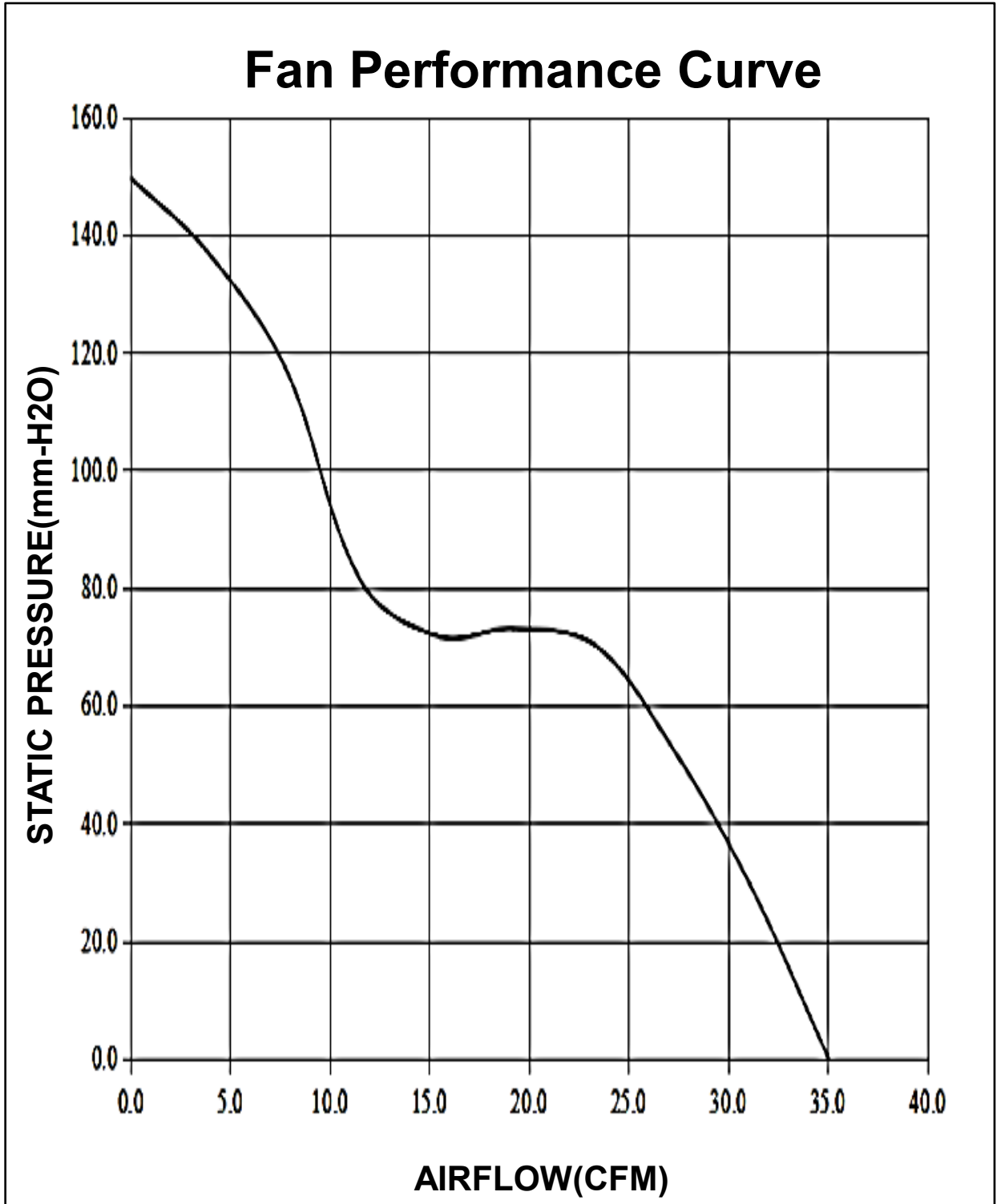



LIFE EXPECTANCY

JARO MODEL: JHD0402812VBBA01(30000)

10-0 LIFE EXPECTANCY

| 故障定義 Product Specification & Failure Definiton | 試驗結果：包含故障時間、數據、統計、...等 Test Result : Including Time Of Failure、Datum、Statistics、... ect. | | | | | | | | | | | | | | | | | | | | | | | | | | | | | | | | | | | | | | | | | | | | | | |
|---|--|---------|---------|---------|---------|--------|---|---|--------|--------|--------|--------|---------|--------|---|---|---|---|---|----|--|---|---------|---------|---------|---------|---------|--|--|----------|--------------------------|-----|-------|---------|--------|-------|--------|-------|-------|--------|-------|-------|--------|-------|-------|-------|------|
| 1.風扇不轉 (Fan Not Work) 2.轉速超出規格30% (Speed Over 30% Origin) 3.電流超出規格30% (Current Over 30% Origin) | $e^{(\Delta H / K) \times (\frac{1}{273+Tl} - \frac{1}{273+Th})}$ • 溫度加速因子 TEMP A.F = • 總試驗時間 Total Test Time = 200000 HRS. | | | | | | | | | | | | | | | | | | | | | | | | | | | | | | | | | | | | | | | | | | | | | | |
| Description : 1.性能測試時點 The Time Of Check Point Start : 0Hr, 500Hrs, 1000Hrs And Finished $70^{\circ}\text{C MTTF} = \frac{\text{Total test time (T)}}{\text{Total failure (r)}}$ GEM TABLE 2. Generalized Exponential Model (for Time-Terminated Test) <table border="1" data-bbox="97 886 465 984"> <tr> <td>r</td> <td>0</td> <td>1</td> <td>2</td> <td>3</td> <td>4</td> <td>5</td> </tr> <tr> <td>M</td> <td>2.3026</td> <td>3.8897</td> <td>5.3223</td> <td>6.6808</td> <td>7.99384</td> <td>9.2747</td> </tr> <tr> <td>r</td> <td>6</td> <td>7</td> <td>8</td> <td>9</td> <td>10</td> <td></td> </tr> <tr> <td>M</td> <td>10.5321</td> <td>11.7709</td> <td>12.9947</td> <td>14.2060</td> <td>15.4066</td> <td></td> </tr> </table> | r | 0 | 1 | 2 | 3 | 4 | 5 | M | 2.3026 | 3.8897 | 5.3223 | 6.6808 | 7.99384 | 9.2747 | r | 6 | 7 | 8 | 9 | 10 | | M | 10.5321 | 11.7709 | 12.9947 | 14.2060 | 15.4066 | | • 查表得 (MTTF By GEM Table) MTTF = 86858 HRS. • 溫度 / TEMP. / MTTF / L10 <table border="1" data-bbox="678 752 1260 990"> <thead> <tr> <th>溫度TE MP.</th> <th>信賴水準90% CONFIDENCE LEVEL</th> <th>L10</th> </tr> </thead> <tbody> <tr> <td>30 °C</td> <td>1559455</td> <td>164153</td> </tr> <tr> <td>40 °C</td> <td>706937</td> <td>74414</td> </tr> <tr> <td>50 °C</td> <td>336561</td> <td>35427</td> </tr> <tr> <td>60 °C</td> <td>167535</td> <td>17635</td> </tr> <tr> <td>70 °C</td> <td>86858</td> <td>9143</td> </tr> </tbody> </table> | 溫度TE MP. | 信賴水準90% CONFIDENCE LEVEL | L10 | 30 °C | 1559455 | 164153 | 40 °C | 706937 | 74414 | 50 °C | 336561 | 35427 | 60 °C | 167535 | 17635 | 70 °C | 86858 | 9143 |
| r | 0 | 1 | 2 | 3 | 4 | 5 | | | | | | | | | | | | | | | | | | | | | | | | | | | | | | | | | | | | | | | | | |
| M | 2.3026 | 3.8897 | 5.3223 | 6.6808 | 7.99384 | 9.2747 | | | | | | | | | | | | | | | | | | | | | | | | | | | | | | | | | | | | | | | | | |
| r | 6 | 7 | 8 | 9 | 10 | | | | | | | | | | | | | | | | | | | | | | | | | | | | | | | | | | | | | | | | | | |
| M | 10.5321 | 11.7709 | 12.9947 | 14.2060 | 15.4066 | | | | | | | | | | | | | | | | | | | | | | | | | | | | | | | | | | | | | | | | | | |
| 溫度TE MP. | 信賴水準90% CONFIDENCE LEVEL | L10 | | | | | | | | | | | | | | | | | | | | | | | | | | | | | | | | | | | | | | | | | | | | | |
| 30 °C | 1559455 | 164153 | | | | | | | | | | | | | | | | | | | | | | | | | | | | | | | | | | | | | | | | | | | | | |
| 40 °C | 706937 | 74414 | | | | | | | | | | | | | | | | | | | | | | | | | | | | | | | | | | | | | | | | | | | | | |
| 50 °C | 336561 | 35427 | | | | | | | | | | | | | | | | | | | | | | | | | | | | | | | | | | | | | | | | | | | | | |
| 60 °C | 167535 | 17635 | | | | | | | | | | | | | | | | | | | | | | | | | | | | | | | | | | | | | | | | | | | | | |
| 70 °C | 86858 | 9143 | | | | | | | | | | | | | | | | | | | | | | | | | | | | | | | | | | | | | | | | | | | | | |
| 3. Herewith, we could assume as right on the basis of above test result. Besides, if the actual test time exceed the required, it comes out that those fans' L ₁₀ expectancy and MTTF are greater than the warrant. MTTF: Mean Time To Failures. It should be used in a non-requirable system setting. Now we show the MTTF in our life report, that's because we will not repair the failed fans during life experiment. MTBF: Mean Time Between Failures. It should be used in a repairable system setting. Basically, MTBF is equal to MTTF, they use same formula to work out a life data. | | | | | | | | | | | | | | | | | | | | | | | | | | | | | | | | | | | | | | | | | | | | | | | |

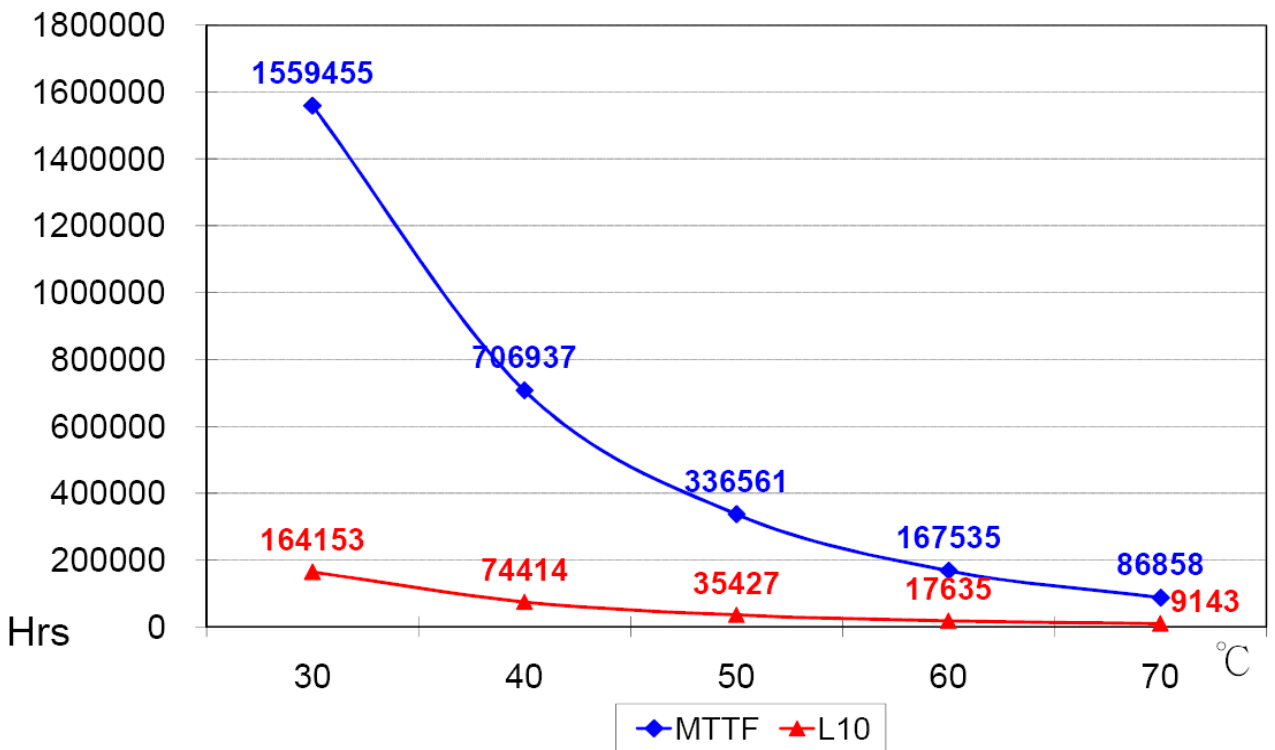



LEAD WIRE DESIGN

JARO MODEL: JHD0402812VBBA01(30000)

11-0 Lead Wire Design

FREQUENCY GENERATOR (FG) SIGNAL
SCHEMATIC

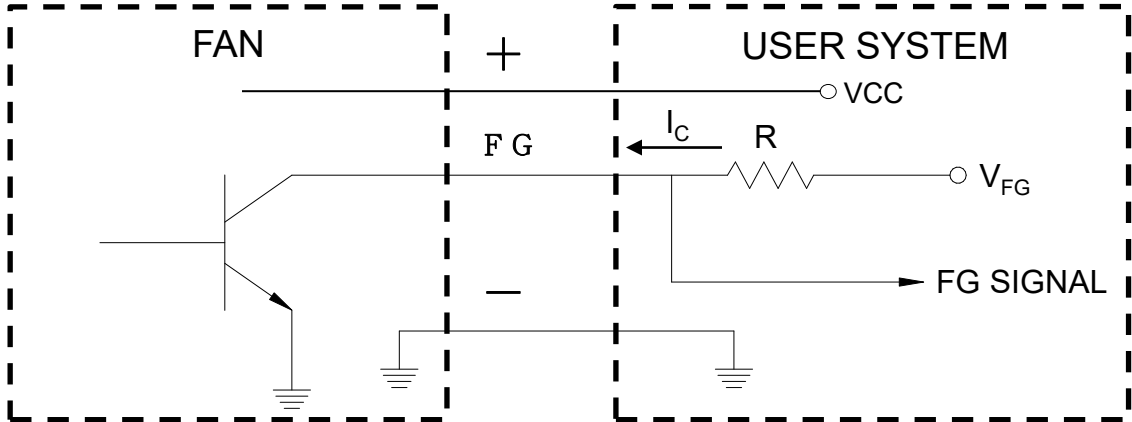

CAUTION:

THE LEAD WIRE OF FG SIGNAL CAN NOT TOUCH
THE LEAD WIRE OF POSITIVE OR NEGATIVE

SIGNAL SPECIFICATION:

OUTPUT TYPE: OPEN COLLECT

V_{FG} MAXIMUM VOLTAGE= 13.2V

I_C MAXIMUM CURRENT= 6mA

LOW LEVEL VOLTAGE= 0.7V MAX

$R \geq V_{FG} / I_C$

FREQUENCY GENERATOR WAVEFORM

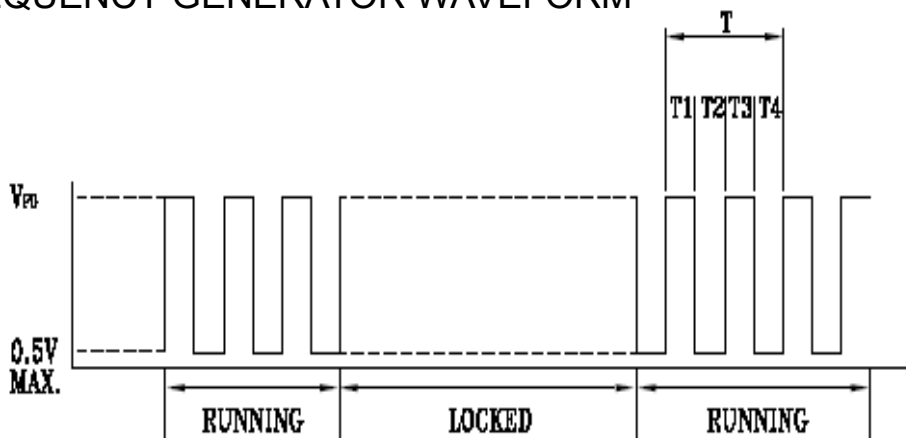

$$T = T_1 + T_2 + T_3 + T_4 = 60/N(\text{Sec})$$

N: SPEED (RPM)



PWM CURVE

JARO MODEL: JHD0402812VBBA01(30000)

12-0 PWM CURVE

PWM CONTROL

SIGNAL DESCRIPTION

1. CONTROL SIGNAL: PWM CONTROL
2. SIGNAL TYPE:
INPUT HIGH LEVEL VOLTAGE: MIN. >2.6V , MAX.<5.0V
INPUT LOW LEVEL VOLTAGE: MAX.<0.4V
3. PWM FREQUENCY RANGE: 2K~40KHZ
4. MAX. SINK CURRENT: 8mA

FAN SPEED CONTROL

1. FAN INPUT VOLTAGE: 12 VDC
2. PWM FREQUENCY : 25 KHZ
3. THE FAN SPEED SHOULD RUN AT FULL SPEED GIVEN PWM 100% DUTY CYCLE INPUT.
4. THE FAN SPEED SHOULD RUN AT ZERO SPEED GIVEN BELOW PWM 0 % DUTY CYCLE INPUT.
5. THE FAN WILL GO TO FULL SPEED WHEN IF THE CONTROL SIGNAL IS DISCONNECTED.
6. THE FAN SPEED WILL SPIN AT MAXIMUM WHEN THE LEAD WIRE OF PWM SIGNAL DISCONNECTED.
7. THE FAN WILL BE ABLE TO START WHEN THE DUTY CYCLE IS 10%.

PWM DUTY VS RPM CHART.

| Duty (%) | Speed R.P.M (REF) | TYPICAL CURRENT(A) | MAX CURRENT(A) |
|----------|-------------------|--------------------|----------------|
| 0 | 0 | 0.02 | 0.03 |
| 100 | 30000±10% | 1.95 | 2.34 |

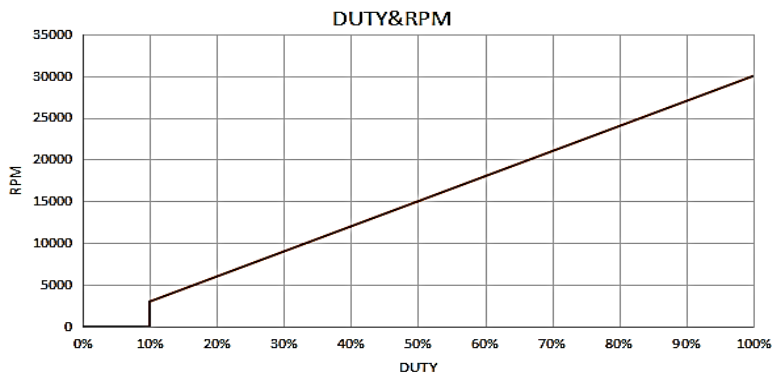

JARO MODEL: JHD0402812VBBA01(30000)

NOTICE FOR OPERATION

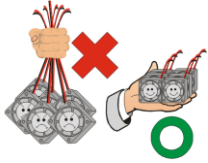

1

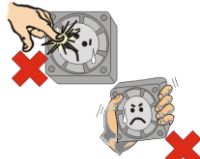

2

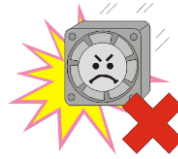

3



4

1. Hold the fan by frame side.
Do not hold lead wires.(Fig.1)
2. Do not touch or press on the impeller.
Do not crush the frame. (Fig.2)
3. Do not drop the fan on the ground.
Hit the frame may cause the fan damaged. (Fig.3)
4. Connect the power cord properly and apply voltage according to specification. (Fig.4)

NOTICE FOR ASSEMBLY AND AMBIENT CONDITIONS

1. When applying our fan your device, please check thoroughly any variation of EMC, temperature rise, life data, quality, etc. of this product by shock/drop/vibration testing, etc. If there is any problem or accident in connection with this product, it should be mutually discussed and checked by both parties.
2. Take proper care for handling this fan. Components such as fan holders or bearings may be damaged by fingers touch or other objects. Additionally, static electricity (ESD) may damage the internal circuits of the fan.
3. DO NOT operate this fan in proximity to hazardous materials such as organic silicon, cyanogen, formalin, phenol, or corrosive gas environments. Any hazardous materials flow to the fan side may cause damaged or malfunction.
4. JARO recommends that you protect this fan from exposure to outside elements such as dust, condensation, humidity or insects.
Exposure of this fan to outside elements such as dust, condensation, humidity or insects may affect its performance and may cause safety hazards. JARO does not guarantee the damage to the product caused by outside elements.
5. This fan must be installed properly and securely. Improper mounting may cause harsh resonance, vibration, and noise. If you have any question about fan mounting, please discuss with JARO if you are not sure the correct mounting method.
6. DO NOT use or store the fan with higher humidity and temperature specified in spec.
The fan must be stored with the attached specifications regarding storage temperature. If this fan is stored for more than 6 months, JARO recommends to perform functional testing before using. Please contact JARO if you are not sure how to perform functional test.
7. The "Life Expectancy" of this fan has not been evaluated for use in combination with any end application. Therefore, the Life Expectancy Test Reports (L10 and MTTF Report) that relate to this fan are only for reference.
8. Fan guards may prevent injury during handling or installation of the fan.