



JARO THERMAL

SPECIFICATION FOR APPROVAL

Customer :
Customer Part No. :
Description : Thermal module
JARO Model No. : JSC00092 REV.A
Sample Issue No. :
Sample Issue Date :
 Preliminary Specification
 Formal Specification

PREPARED BY :	Sidney Li	DATE :	10/08/2021
CHECKED BY :	Chris Hsu	DATE :	10/08/2021
APPROVED BY :	Chris Hsu	DATE :	10/08/2021

PLEASE SEND ONE COPY OF THIS SPECIFICATION BACK AFTER YOU SIGNED APPROVAL FOR PRODUCTION PRE-ARRANGEMENT.

By: _____ (printed)

Signature: _____

Date: _____



Jaro Thermal USA office
6600 Park of Commerce Blvd.
Boca Raton, Florida 33487
www.jarothermal.com
Ph: 561-241-6700
Fx: 561-241-3328

Jaro Thermal Taiwan office
Building H, No.119-1, Zhudong Rd., Renwu
Dist., Kaohsiung City, Taiwan 81448
www.jarothermal.com
Ph: +886-7-375-2053
Fx: +886-7-374-7403

We keep the world cool™



JARO MODEL NUMBER

JSC00092



Revision of Spec History

Revision	Change Content	Change page	DATE	BY
0	Created SPEC		10/05/2018	Terry Chang
A	The IC of fan is changed to Prolific PT3923-A and update the model name for fan.	3 and 4	10/08/2021	Sidney Li

Notice:

1. This specification will be changed base on Jaro Thermal 's notification. Please refer to update revision of spec by contacting Jaro Thermal.
2. This specification clarify all the mechanical & electrical characteristics of DC brushless fans & AC brushless fans & heat sink.
3. The specification of this product is described in detailed document. Please do not use the fan without proper usage. Please contact Jaro Thermal if you have special requirement which is not listed on this specification.
4. Any of change, please contact Jaro Thermal to change the new revision in order to make sure all technical data is up to date. Any ECN change will be followed by sending new update specification.

1. Assembly drawing

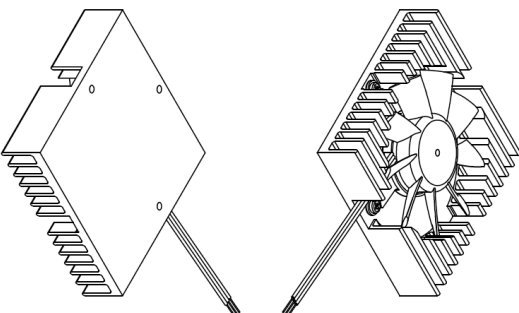
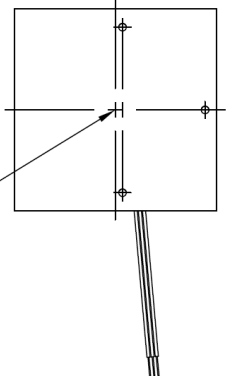
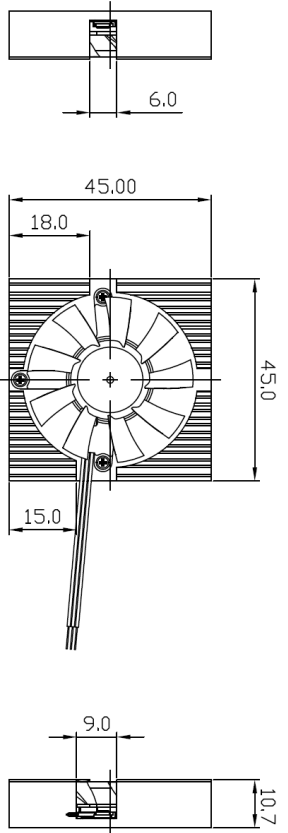

ISOMETRIC VIEW
SCALE 1:1

- NOTES:
1. THIS DRAWING CONTAINS OVERALL DIMENSIONS ONLY, REFER TO 3D CAD DATABASE FOR COMPLETE PART INFORMATION.
 2. PARTS TO BE CLEAN AND FREE OF CRACKS, FOREIGN MATTER, NO OIL OR LUBRICANTS ON THE SURFACE.
 3. ALL DIMENSIONS SHOWN SHALL BE CHECKED AT FIRST ARTICLE INSPECTION.
 4. REMOVE ALL BURRS AND SHARP EDGES.
 5. FINISHED PRODUCT TO BE ROHS COMPLIANT.

REVISIONS			
REV.	COMMENT	DATE	APPROVED
0	INITIAL RELEASE	2018-10-05	CHRIS
A	THE IC OF FAN IS CHANGED TO PDI01FC F7325-A AND UPDATE THE MODEL NAME FOR FAN.	2021-10-08	CHRIS

DIMENSIONAL TOLERANCE		DRAWN		TITLE	
DECIMAL PLACES	MILLIMETERS	INCHES		COOLER ASSEMBLY	
.X	± 0.040	-	CHECKED	MATERIAL	
.XX	± 0.020	-		FINISH	
UNLESS OTHERWISE SPECIFIED				CUS. PART NO.	
ANGULAR DIMENSIONS	± 1.0°	THIRD ANGLE PROJECTION	APPROVED	CUS. REV.	
SCALE	1:1	UNIT	mm	SIZE	A3

STIDNEY	CHRIS	CHRIS
PART NO.	JSC00092	REV.
	A	
SHEET	1	OF
	4	
DATE	2018-10-05	

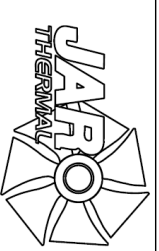

2. Exploded views

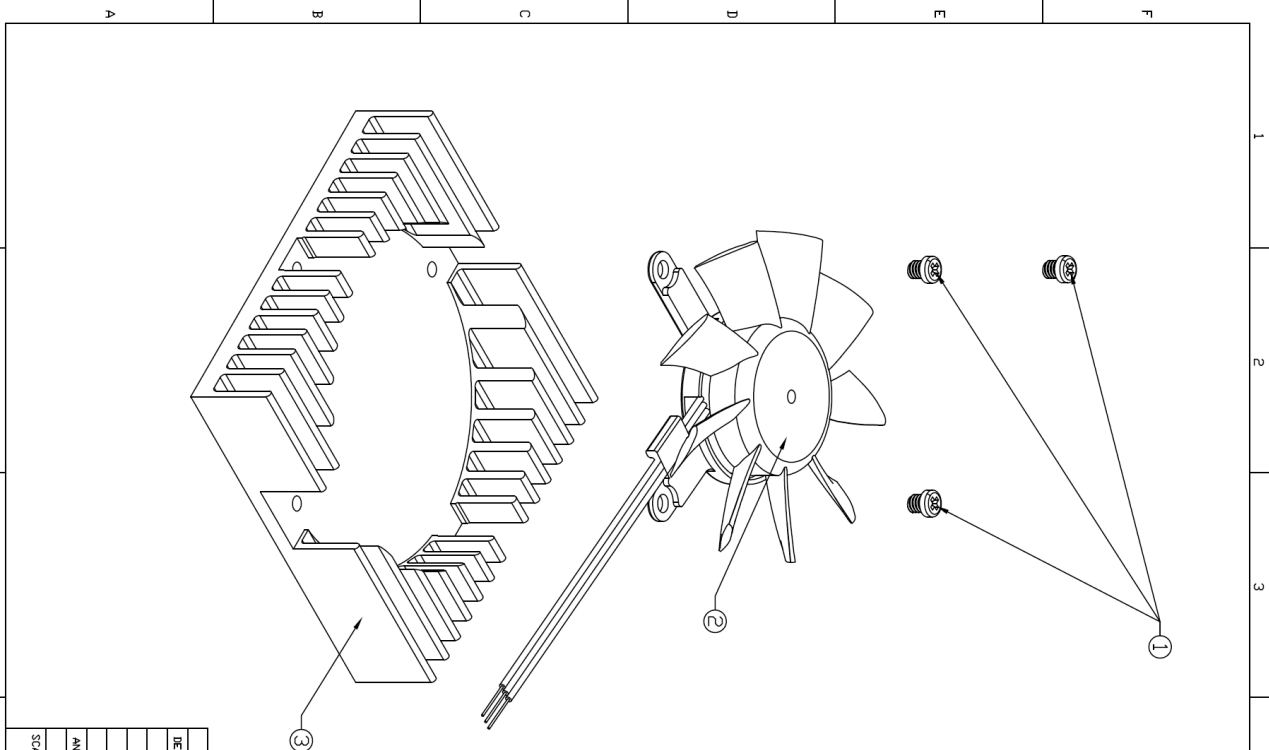

REVISIONS			
REV.	COMMENT	DATE	APPROVED
0	INITIAL RELEASE	2018-10-05	CHRIS
A	THE IC OF FAN IS CHANGED TO PROLIFIC FT3923-A AND UPDATE THE MODEL NAME FOR FAN.	2021-10-08	CHRIS

ITEM	QTY.	DESCRIPTION	TITLE	MATERIAL	REMARK
3	1	HEAT SINK	EXPLODED VIEWS	AL 6063-T5	FINISH: BLACK ANODIZE
2	1	FAN ASSEMBLY	EXPLODED VIEWS	-	JPY0400812MA3A01C(WY)
1	3	M2X2.0 SCREW	EXPLODED VIEWS	SAE 1018	FINISH: NICKEL PLATING

DIMENSIONAL TOLERANCE	
DECIMAL PLACES	MILLIMETERS
.	± 0.50
.X	± 0.20
.XX	± 0.20

UNLESS OTHERWISE SPECIFIED	
ANGULAR DIMENSIONS	THIRD ANGLE PROJECTION
± 1.0°	⌀

SCALE	UNIT	SIZE
2:1	mm	A3

DRAWN		CHECKED		APPROVED	
CHRIS	CHRIS	CHRIS	CHRIS	CHRIS	CHRIS

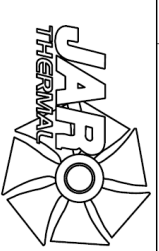

PART NO.	REV.	SHEET	OF	DATE
JSC00092	A	2	4	2018-10-05

3. Individual component drawing

1) Heat sink

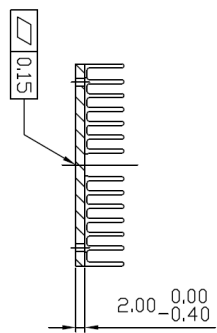
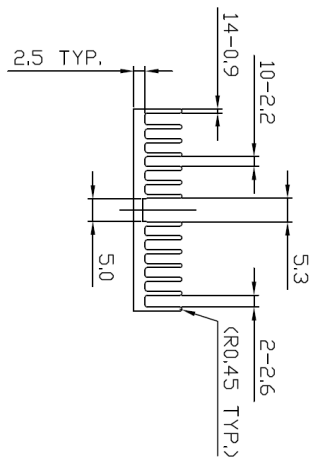
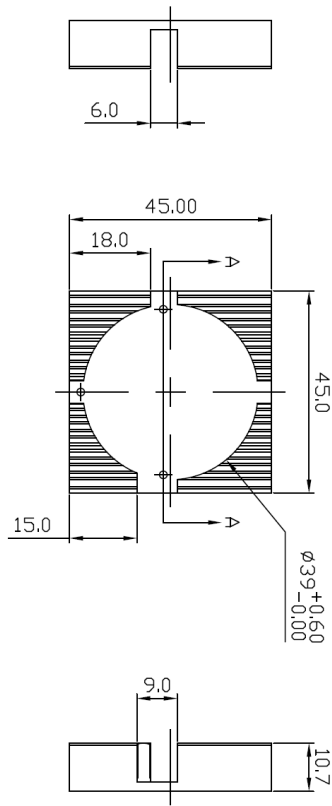

SECTION A-A

ISOMETRIC VIEW
SCALE 1:1

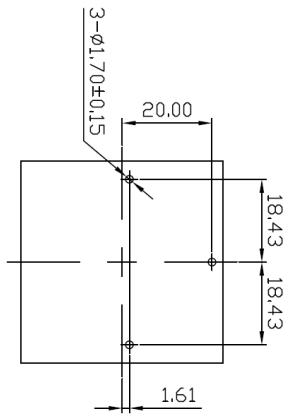
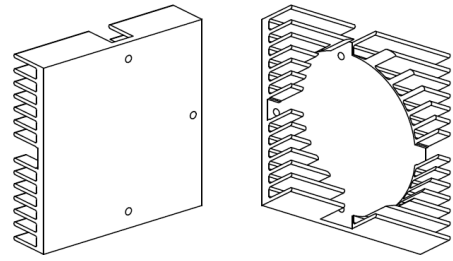

- NOTES:
1. THIS DRAWING CONTAINS OVERALL DIMENSIONS ONLY. REFER TO 3D CAD DATABASE FOR COMPLETE PART INFORMATION.
 2. PARTS TO BE CLEAN AND FREE OF CRACKS, FOREIGN MATTER, NO OIL OR LUBRICANTS ON THE SURFACE.
 3. ALL DIMENSIONS SHOWN SHALL BE CHECKED AT FIRST ARTICLE INSPECTION.
 4. REMOVE ALL BURRS AND SHARP EDGES.
 5. FINISHED PRODUCT TO BE ROHS COMPLIANT.

DIMENSIONAL TOLERANCE		DRAWN		TITLE	
DECIMAL PLACES	MILLIMETERS	INCHES		HEAT SINK	
.X	± 0.50	-	CHECKED	AL 6063-T5	
.XX	± 0.20	-	CHECKED	FINISH	BLACK ANODIZE
UNLESS OTHERWISE SPECIFIED				CUS. PART NO.	CUS. REV.
ANGULAR DIMENSIONS	THIRD ANGLE PROJECTION		APPROVED		
SCALE	UNIT	SIZE		PART NO.	REV.
1:1	mm	A3	CHRIS	JSHAE00333	A

REVISIONS			
REV.	COMMENT	DATE	APPROVED
0	INITIAL RELEASE	2018-10-05	CHRIS

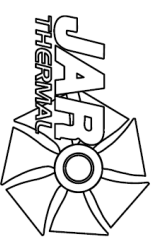

2) M2x2.0 Screw

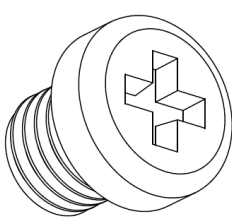
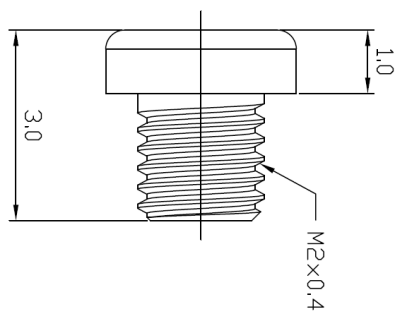
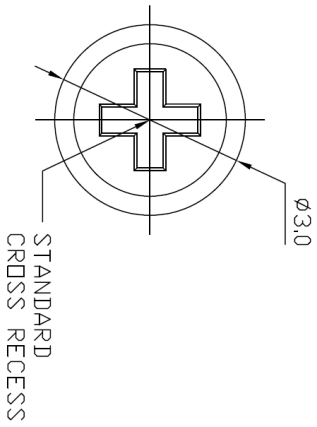

ISOMETRIC VIEW
SCALE 10:1

REVISIONS			
REV.	COMMENT	DATE	APPROVED
0	INITIAL RELEASE	2018-10-05	CHRIS

- NOTES:
1. MATERIAL: SAE 1018 ; FINISH: NICKEL PLATING
 2. THIS DRAWING CONTAINS OVERALL DIMENSIONS ONLY. REFER TO 3D CAD DATABASE FOR COMPLETE PART INFORMATION.
 3. PARTS TO BE CLEAN AND FREE OF CRACKS, FOREIGN MATTER. NO OIL OR LUBRICANTS ON THE SURFACE.
 4. ALL DIMENSIONS SHOWN SHALL BE CHECKED AT FIRST ARTICLE INSPECTION.
 5. REMOVE ALL BURRS AND SHARP EDGES.
 6. FINISHED PRODUCT TO BE ROHS COMPLIANT.

DIMENSIONAL TOLERANCE		DRAWN		TITLE	
DECIMAL PLACES	MILLIMETERS	INCHES	CHECKED	MATERIAL	M2x2.0 SCREW
.	± 0.50	-	SIDNEY	SEE NOTES	
.X	± 0.30	-	CHRIS	FINISH	SEE NOTES
.XX	± 0.20	-	CHRIS	CUS. PART NO.	CUS. REV.
UNLESS OTHERWISE SPECIFIED					
ANGULAR DIMENSIONS		THIRD ANGLE PROJECTION	APPROVED		
± 1.0°			CHRIS	PART NO.	JSC00092
SCALE	10:1	UNIT	mm	SIZE	A4

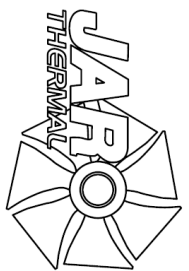



JARO THERMAL

SPECIFICATION FOR APPROVAL

Customer :
Customer Part No. :
Description : DC FAN
JARO Model No. : JPY0400812MA3A01(CWY) REV.A
Sample Issue No. :
Sample Issue Date :
 Preliminary Specification
 Formal Specification

PREPARED BY :	Franco Huang	DATE :	09/10/2021
CHECKED BY :	Ivan Chen	DATE :	09/10/2021
APPROVED BY :	Jay Su	DATE :	09/10/2021

PLEASE SEND ONE COPY OF THIS SPECIFICATION BACK AFTER YOU SIGNED APPROVAL FOR PRODUCTION PRE-ARRANGEMENT.

By: _____ (printed)

Signature: _____

Date: _____



Jaro Thermal USA office
6600 Park of Commerce Blvd.
Boca Raton, Florida 33487
www.jarothermal.com
Ph: 561-241-6700
Fx: 561-241-3328

Jaro Thermal Taiwan office
Building H, No.119-1, Zhudong Rd., Renwu
Dist., Kaohsiung City, Taiwan 81448
www.jarothermal.com
Ph: +886-7-375-2053
Fx: +886-7-374-7403

We keep the world cool™



JARO SPEC NUMBER	

Revision of Spec History

Revision	Change Content	Change page	DATE	BY
0	Created SPEC		10/05/2018	Caleb Huang
A	The IC changed to Prolific PT3923-A and updated JARO model name.	9~17	09/10/2021	Franco Huang

Notice:

1. This specification will be changed base on Jaro Thermal 's notification. Pls refer to update revision of spec by contacting Jaro Thermal.
2. This specification clarify all the mechanical & electrical characteristics of DC brushless fans & AC brushless fans & Heatsink.
3. The specification of this product is described in detailed document. Pls do not use the fan without proper usage. Pls contact Jaro Thermal if you have special requirement which is not listed on this specification.
4. Any of change, pls contact Jaro Thermal to change the new revision in order to make sure all technical data is up to date. Any ECN change will be followed by sending new update spec.



SPECIFICATION



Jaro Model : JPY0400812MA3A01(CWY)

Samples attached : pcs

Safety Approval : CE

FEATURES

<input type="checkbox"/>	FG SIGNAL	<input type="checkbox"/>	IP-55 RATED
<input type="checkbox"/>	RD SIGNAL	<input checked="" type="checkbox"/>	V HIGH TEMP RATED
<input type="checkbox"/>	PWM	<input type="checkbox"/>	

DIMENSIONS	:	40	X	40	X	08	mm
BEARING TYPE	:	AFB					
MOTOR PROTECTION	:	BY	IC				
RATED VOLTAGE	:	12.0	VDC				
OPERATING VOLTAGE RANGE	:	10.8	~	13.2	VDC		
START-UP VOLTAGE	:	9.0	VDC , (AT RATED VOLTAGE)				
REAL CURRENT	:	0.08	Amp				
REAL POWER	:	0.96	Watt				
RATED CURRENT	:	0.10	Amp +10% MAX				
RATED POWER	:	1.20	Watt				
RATED SPEED	:	5000	RPM		± 20 %		
		(IN FREE AIR AT RATED VOLTAGE)					
AIR FLOW	:	7.12	CFM	(min.:	5.70	CFM)	
AIR FLOW	:	0.20	CMM	(min.:	0.16	CMM)	
		(IN FREE AIR AT RATED VOLTAGE)					
STATIC AIR PRESSURE	:	0.09	InH2O	(min.:	0.06	InH2O)	
STATIC AIR PRESSURE	:	2.31	mmH2O	(min.:	1.48	mmH2O)	
		(IN FREE AIR AT RATED VOLTAGE)					
NOISE LEVEL	:	26.0	dB(A)	(MAX.:	30.0	dB(A)	
LIFE EXPECTANCY	:	50000	Hours	at 40°C / 65% RH			
NET WEIGHT	:	5	Gram				



The standard of Jaro Thermal's fan relative humidity is 65%, and the temperature is 25°C for the standard testing. If you have any question, pls refer to environmental condition on 5-0 first. Other special request pls contact Jaro Thermal for spec checking.



SPECIFICATION

JARO MODEL: JPY0400812MA3A01(CWY)

1-0 MATERIAL

- 1-1 Bracket Material - PBT 94V0 (Black)
- 1-2 Fan Blade Material - PBT 94V0 (Black)
- 1-3 Other material – See 8.0 Dimension Drawing
- 1-4 Environmental Standard
 - [V] RoHS
 - [V] REACH
 - [] Halogen Free

2-0 FAN VOLTAGE CURRENT, LOCK ROTOR, AIR FLOW, STATIC PRESSURE & NOISE DEFINITION

- 2-1 Start Voltage - By sudden switching ON fan is start to rotate.
- 2-2 Input Power - Input Power shall be measured after 3 minutes for continuing rotation by rated voltage.
- 2-3 Rated Current - Rated Current shall be measured after 3 minutes by continuing rotation by rated voltage.
- 2-4 Rated Speed - Rated Speed shall be measured after 3 minutes for continuing rotation by rated voltage.
- 2-5 Locked Rotor Current : Locked current shall be measured within one minute of rotor locked, after 3 minutes by continuing rotation at rated voltage in clean air.
- 2-6 Air Flow & Static Pressure : The air flow data and static pressures should be determined in accordance with AMCA-210 standard or DIN24163 specification in chamber testing and record the test record.
- 2-7 Noise Level : The measurement of noise level is carried out with reference to CNS8753 in a semi-anechoic chamber with the microphone positioned 1 meter from the air intake. Testing fan shall be hung in clean air .

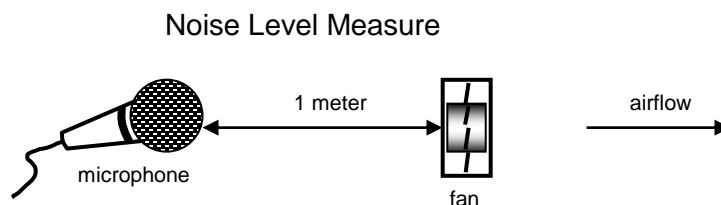



SPECIFICATION

JARO MODEL: JPY0400812MA3A01(CWY)

3-0 FAN FUNCTION DEFINITION

3-1 Rotation Direction - Counterclockwise from impeller side.

3-2 Lock Rotor Condition

No damage for winding or electronic in locked rotor condition. And no damage after 72hrs continuing for lock rotor condition.

3-3 Auto Restart

Fan will automatic restart without any abnormal usage.

3-4 Dead Angle

Switch the fan change from off to on condition. Restart the fan, it will automatic restart by fan power on.

3-5 Polarity

Check the voltage and polarity before turn on the power to the fan.

3-6 Insulation Resistance

Do not use < 10M ohm between housing and positive end of lead wire (red) at 500V DC.

3-7 Dielectric Strength

No damage should be found at 500 VAC for 60 seconds, measured with 1mA trip current between housing and positive end of lead wire.

4-0 FAN PACKAGE TEST

4-1 Free Drop Shock

Base on Jaro Thermal's standard package, the fan package will test and drops on any three faces - Test standard is 30cm height. The base is wood board for 10mm thick.

5-0 FAN ENVIRONMENTAL CONDITION

5-1 Operating Temperature / Humidity

-10°C to +85°C at humidity 5% to 90% Relative humidity.

• 5-2 Humidity

After 96 hours, 95% RH, 40+/-2°C per MIL-STD-202F, method 103B humidity test, the measured data on insulation resistance and dielectric strength shall meet the specification.

5-3 Storage Temperature

All function shall be normal after 500 hours storage at -40°C to +85 °C with a 24 hour recovery period at room temperature. Humidity 5% to 95% Relative humidity

- 5-4 Do not store this fan in an environment with high humidity. This fan must be stored in accordance with the storage temperature. Do not store the fan for over 6 months; If this fan is stored for more than 6 months, JARO THERMAL recommends functional testing before using.



SPECIFICATION

JARO MODEL: JPY0400812MA3A01(CWY)

5-5 Improper way to disassembled fan will cause the fan get into dust or dip into water. Which will in defects is not covered in the warranty. Do not use the fan in the environment with corrosive air or liquid.

6-0 MASS PRODUCTION SAMPLE PLAN INSPECTION

All fans shall meet the quality inspection under MIL-STD-105E standard list as follow:

Critical 0.25%

Major 1.00%

Minor 2.50%

7-0 FAN USE WITH CAUTION

7-1 Please do not stick a grease and/or an oil to the fan housing or blade which may have a harmful influence by a chemical reaction at high humidity.

7-2 If the fan is reinstalled, please pay special attention to the noise due to the vibration (or resonance).

7-3 During the testing of the fan, please make sure the finger guard is use for your safety.

- 7-4 While the fan is running, please do not lock the fan intentionally for a long time. This will cause overheating by long period locking status. This action will damage the fan.

7-5 Please do not touch and push Fan Blade with fingers or others, fan blade and ball bearings may be damaged and it causes noise defect.

7-6 Do not carry the fan by its lead wires.

7-7 If the fan does not have the polarity protection function, the connection of the colored wires should be red + red, and black + black, or else the fan will be damaged in no time.

7-8 For the models without reverse connection of polarity protection, please do not connect the lead wire in reverse position.

7-9 Please don't install this fan in series with 2x voltage inputs. For example, if a single fan rated at 12V, then don't install two of them in series with 24V input.

7-10 Every specific fan is designed for its certain application (project). Therefore, if you want to use this fan in other application (project), please inform JARO first so that we can confirm whether there is any issue which might be incurred from the reason of this different application (project) or not.

7-11 The "Life Expectancy" of this fan has not been evaluated for use in combination with any end application. Therefore, the Life Expectancy in the Test Reports(L10 and MTTF Report) that relate to this fan is for reference only and shall not construe any kind of warranty of JARO to the life of any specific fan , either expressed or implied.

7-12 The period of product warranty , unless otherwise agreed by JARO in written , shall be 12 months staring from the date of production.



DIMENSION DRAWING

JARO MODEL: JPY0400812MA3A01(CWY)

8-0 DIMENSIONS

All dimensions, Direction of rotation and air flow were specified as per drawing attached.

Description: DC Fan with:

Lead Wire: UL3302 , AWG#30 , 140± 10 mm lead length

Red wire = Positive(+); Black wire = Negative(-); Yellow wire = FG

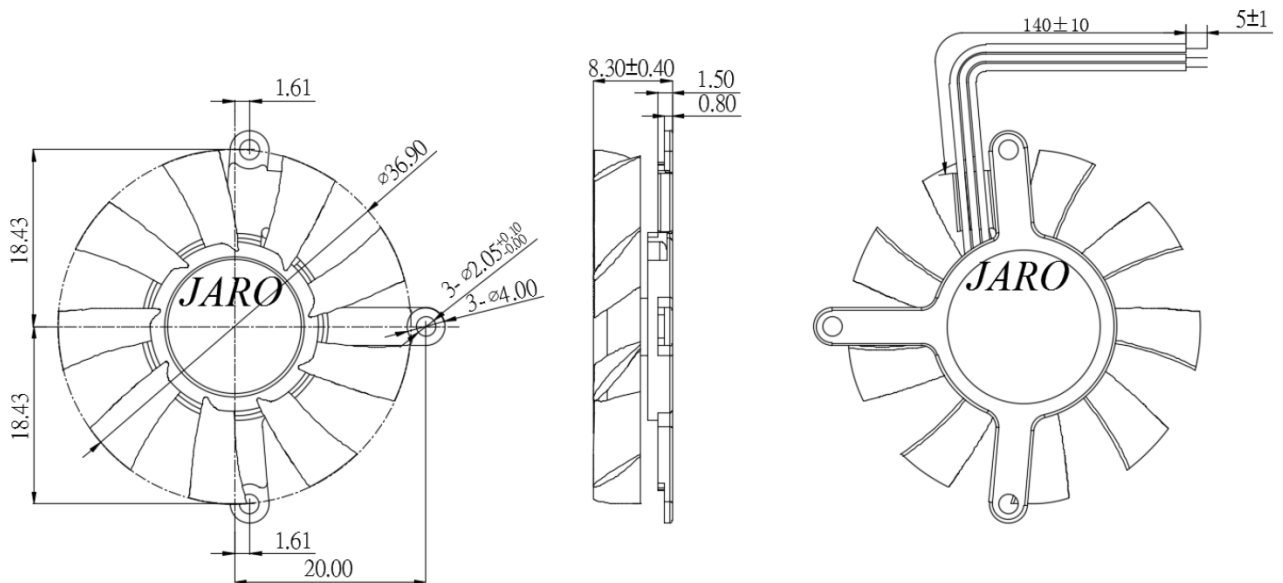

DIAGRAM OF DIMENSIONS: Dimensions in millimeters
NOT TO SCALE. ALL COMPONENTS MUST BE RoHS/REACH COMPLIANT.

Drawing Note: N/A

Safety :CE



PERFORMANCE CURVE

JARO MODEL: JPY0400812MA3A01(CWY)

9-0 PERFORMANCE CURVE

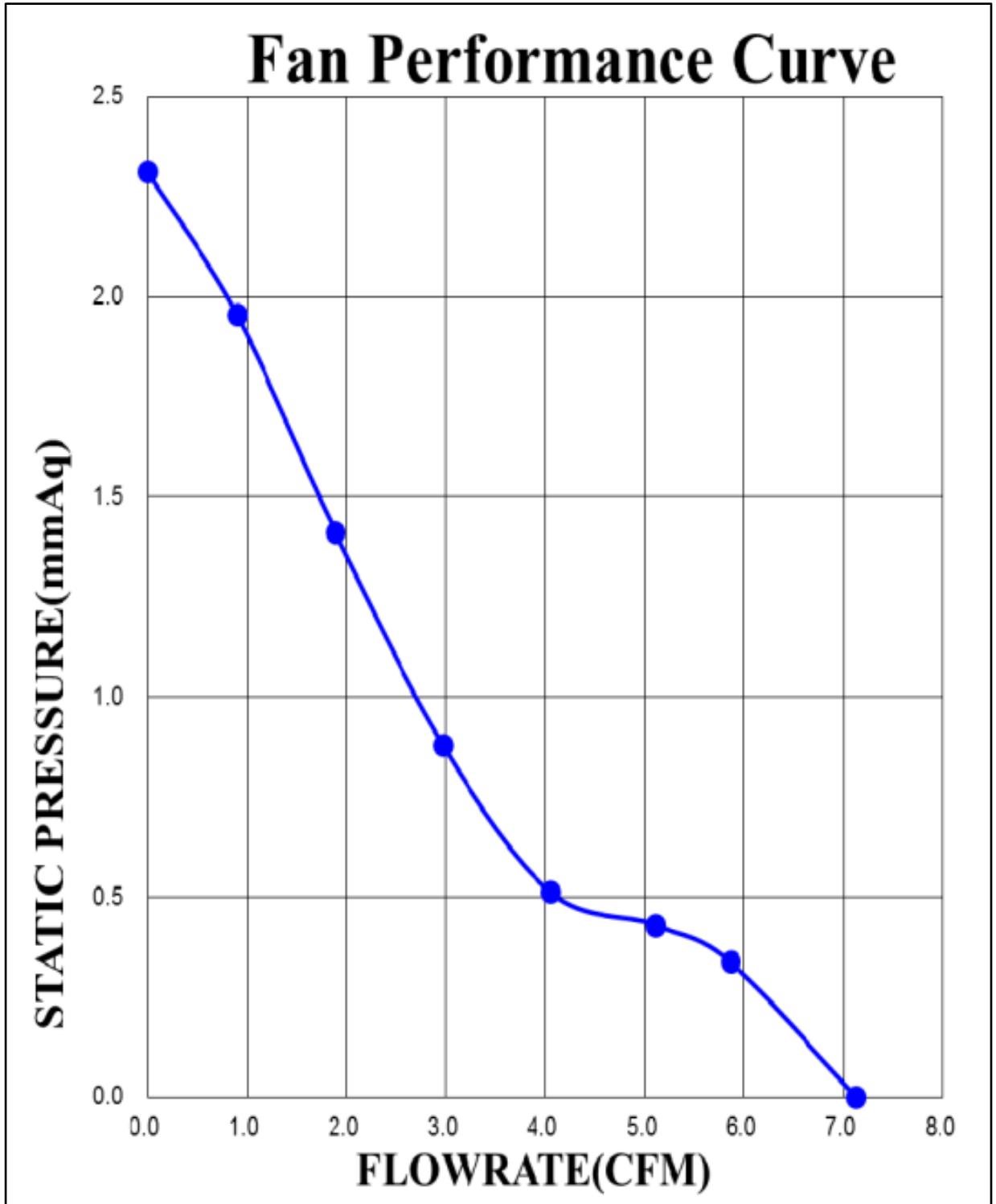



LIFE EXPECTANCY

JARO MODEL: JPY0400812MA3A01(CWY)

10-0 LIFE EXPECTANCY

故障定義 Product Specification & Failure Definiton	試驗結果：包含故障時間、數據、統計、...等 Test Result : Including Time Of Failure、Datum、Statistics、... ect.																		
1.風扇不轉 (Fan Not Work) 2.轉速超出規格30% (Speed Over 30% Origin) 3.電流超出規格30% (Current Over 30% Origin)	<ul style="list-style-type: none"> • 溫度加速因子 TEMP A.F = $e^{(\Delta H / K) \times (\frac{1}{273+Tl} - \frac{1}{273+Th})}$ • 總試驗時間 Total Test Time = 200000 HRS. • 查表得 (MTTF By GEM Table) MTTF = 153620 HRS. 																		
1.性能測試時點 The Time Of Check Point Start : 0Hr, 500Hrs, 1000Hrs And Finished	<ul style="list-style-type: none"> • 溫度 / TEMP. / MTTF / L10 <table border="1" data-bbox="682 737 1268 965"> <thead> <tr> <th>溫度 TEMP.</th> <th>信賴水準90% CONFIDENCE LEVEL</th> <th>L10</th> </tr> </thead> <tbody> <tr> <td>30 ℃</td> <td>1065201</td> <td>112126</td> </tr> <tr> <td>40 ℃</td> <td>536033</td> <td>56424</td> </tr> <tr> <td>50 ℃</td> <td>281461</td> <td>29627</td> </tr> <tr> <td>60 ℃</td> <td>153620</td> <td>16171</td> </tr> <tr> <td>70 ℃</td> <td>86858</td> <td>9143</td> </tr> </tbody> </table>	溫度 TEMP.	信賴水準90% CONFIDENCE LEVEL	L10	30 ℃	1065201	112126	40 ℃	536033	56424	50 ℃	281461	29627	60 ℃	153620	16171	70 ℃	86858	9143
溫度 TEMP.	信賴水準90% CONFIDENCE LEVEL	L10																	
30 ℃	1065201	112126																	
40 ℃	536033	56424																	
50 ℃	281461	29627																	
60 ℃	153620	16171																	
70 ℃	86858	9143																	
2. Herewith, we could assume as right on the basis of above test result. Besides, if the actual test time exceed the required, it comes out that those fans' L ₁₀ expectancy and MTTF are greater than the warrant. MTTF: Mean Time To Failures. It should be used in a non-requirable system setting. Now we show the MTTF in our life report, that's because we will not repair the failed fans during life experiment. MTBF: Mean Time Between Failures. It should be used in a repairable system setting. Basically, MTBF is equal to MTTF, they use same formula to work out a life data.																			

MTTF & L10 Curve

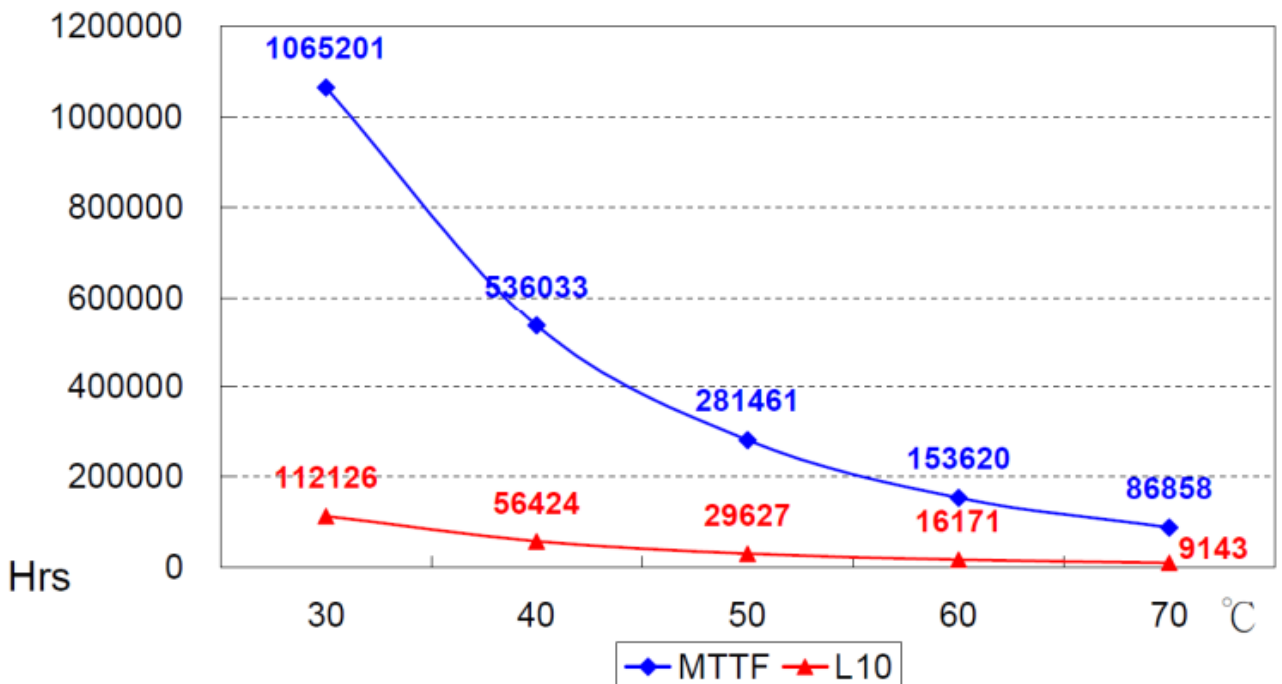

JARO MODEL: JPY0400812MA3A01(CWY)

11-0 Lead Wire Design

Output method - open collector method:

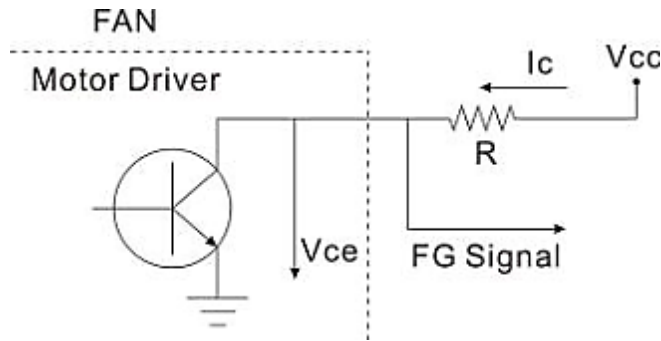

Circuit specification:

Specification

$$V_{cc} = 13.2V(\text{Max})$$

$$V_{ce}(\text{sat}) = 1.0V(\text{Max})$$

$$I_c = 5mA(\text{Max})$$

$$R \geq V_{cc}/I_c$$

Frequency Generator Waveform:

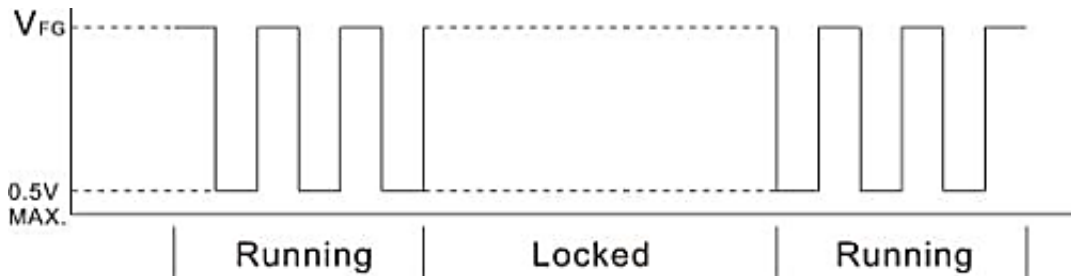

Fan Running for 2 pulse

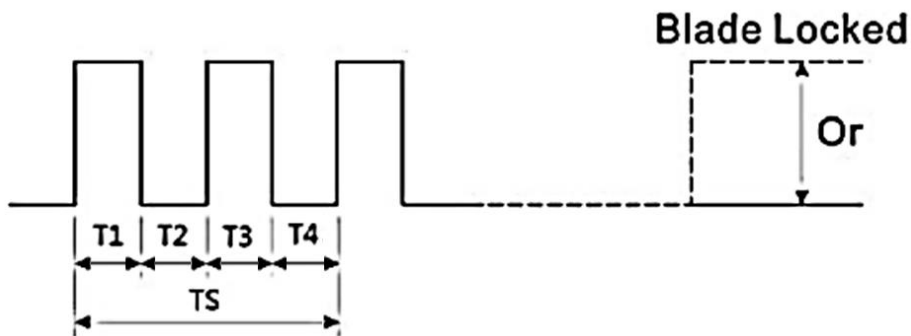

$$N = \text{R.P.M}$$

$$T_1 = T_2 = T_3 = T_4 = 1/4 TS$$

$$TS = 60/M \text{ (second)}$$

*2 Pulses for 1 rotation

JARO MODEL: JPY0400812MA3A01(CWY)

NOTICE FOR OPERATION

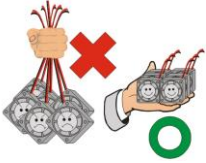

1



2

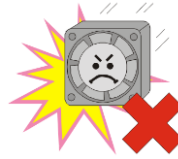

3



4

1. Hold the fan by frame side.
Do not hold lead wires.(Fig.1)
2. Do not touch or press on the impeller.
Do not crush the frame. (Fig.2)
3. Do not drop the fan on the ground.
Hit the frame may cause the fan damaged. (Fig.3)
4. Connect the power cord properly and apply voltage according to specification. (Fig.4)

NOTICE FOR ASSEMBLY AND AMBIENT CONDITIONS

1. When applying our fan your device, please check thoroughly any variation of EMC, temperature rise, life data, quality, etc. of this product by shock/drop/vibration testing, etc. If there is any problem or accident in connection with this product, it should be mutually discussed and checked by both parties.
2. Take proper care for handling this fan. Components such as fan holders or bearings may be damaged by fingers touch or other objects. Additionally, static electricity (ESD) may damage the internal circuits of the fan.
3. DO NOT operate this fan in proximity to hazardous materials such as organic silicon, cyanogen, formalin, phenol, or corrosive gas environments. Any hazardous materials flow to the fan side may cause damaged or malfunction.
4. JARO recommends that you protect this fan from exposure to outside elements such as dust, condensation, humidity or insects.
Exposure of this fan to outside elements such as dust, condensation, humidity or insects may affect its performance and may cause safety hazards. JARO does not guarantee the damage to the product caused by outside elements.
5. This fan must be installed properly and securely. Improper mounting may cause harsh resonance, vibration, and noise. If you have any question about fan mounting, please discuss with JARO if you are not sure the correct mounting method.
6. DO NOT use or store the fan with higher humidity and temperature specified in spec.
The fan must be stored with the attached specifications regarding storage temperature. If this fan is stored for more than 6 months, JARO recommends to perform functional testing before using. Please contact JARO if you are not sure how to perform functional test.
7. The "Life Expectancy" of this fan has not been evaluated for use in combination with any end application. Therefore, the Life Expectancy Test Reports (L10 and MTTF Report) that relate to this fan are only for reference.
8. Fan guards may prevent injury during handling or installation of the fan.