



JARO THERMAL

SPECIFICATION FOR APPROVAL

Customer :
Customer Part No. :
Description : Thermal module
JARO Model No. : JSC00123 REV.A
Sample Issue No. :
Sample Issue Date :
 Preliminary Specification
 Formal Specification

PREPARED BY :	Franco Huang	DATE :	09/10/2021
CHECKED BY :	Chris Hsu	DATE :	09/10/2021
APPROVED BY :	Chris Hsu	DATE :	09/10/2021

PLEASE SEND ONE COPY OF THIS SPECIFICATION BACK AFTER YOU SIGNED APPROVAL FOR PRODUCTION PRE-ARRANGEMENT.

By: _____ (printed)

Signature: _____

Date: _____



Jaro Thermal USA office
6600 Park of Commerce Blvd.
Boca Raton, Florida 33487
www.jarothermal.com
Ph: 561-241-6700
Fx: 561-241-3328

Jaro Thermal Taiwan office
Building H, No.119-1, Zhudong Rd., Renwu
Dist., Kaohsiung City, Taiwan 81448
www.jarothermal.com
Ph: +886-7-375-2053
Fx: +886-7-374-7403

We keep the world cool™



JARO MODEL NUMBER

JSC00123



Revision of Spec History

Revision	Change Content	Change page	DATE	BY
0	Created SPEC		07/19/2021	Caleb Huang
A	Changed fan PN	3,4,11 and 12	09/10/2021	Franco Huang

Notice:

1. This specification will be changed base on Jaro Thermal 's notification. Please refer to update revision of spec by contacting Jaro Thermal.
2. This specification clarify all the mechanical & electrical characteristics of DC brushless fans & AC brushless fans & heat sink.
3. The specification of this product is described in detailed document. Please do not use the fan without proper usage. Please contact Jaro Thermal if you have special requirement which is not listed on this specification.
4. Any of change, please contact Jaro Thermal to change the new revision in order to make sure all technical data is up to date. Any ECN change will be followed by sending new update specification.

1. Assembly drawing

REVISIONS			
REV.	COMMENT	DATE	APPROVED
0	INITIAL RELEASE	2021-07-19	CHRIS
A	CHANGED FAN PN	2021-08-25	CHRIS

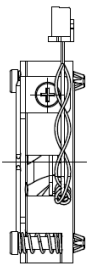

F

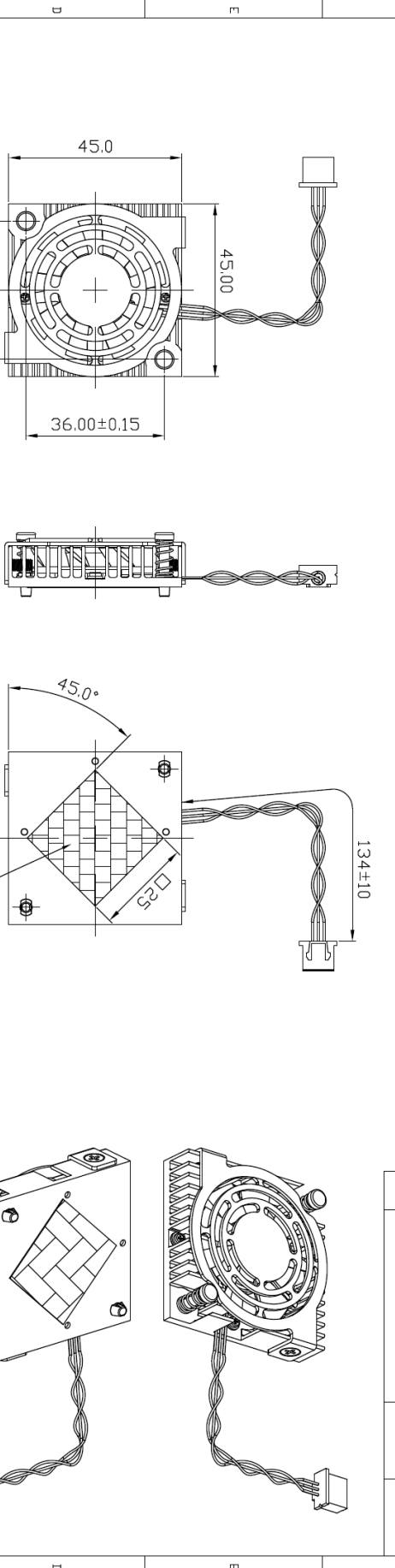

E



D

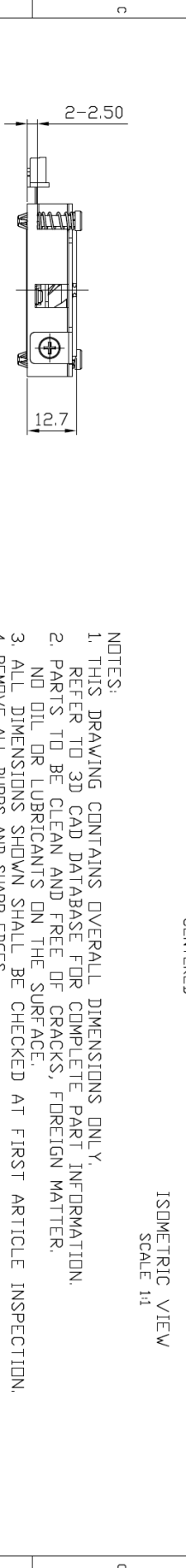

C

NOTES:
 1. THIS DRAWING CONTAINS OVERALL DIMENSIONS ONLY. REFER TO 3D CAD DATABASE FOR COMPLETE PART INFORMATION.
 2. PARTS TO BE CLEAN AND FREE OF CRACKS, FOREIGN MATTER, NO OIL OR LUBRICANTS ON THE SURFACE.
 3. ALL DIMENSIONS SHOWN SHALL BE CHECKED AT FIRST ARTICLE INSPECTION.
 4. REMOVE ALL BURRS AND SHARP EDGES.
 5. FINISHED PRODUCT TO BE ROHS COMPLIANT.
 6. IMPROPER USE SUCH AS DISASSEMBLING THE PAD/GREASE, BEING COVERED WITH DUST OR DIPPING THE PAD/GREASE IN WATER THAT RESULT IN DEFECT IS NOT COVERED IN THE WARRANTY.
 7. DO NOT USE THE PAD/GREASE IN THE ENVIRONMENT WITH CORROSIVE AIR OR LIQUID. THE PAD/GREASE MUST BE STORED AT ROOM TEMPERATURE CONDITION 22°C (FAHRENHEIT 71.6°F), AND 50% RH.
 8. THE WARRANTY OF THE PAD IS SIX MONTHS AFTER JARD SHIPMENT DATE.

B

DIMENSIONAL TOLERANCE			
DECIMAL PLACES	MILLIMETERS	INCHES	DRAWN
.	± 0.50	-	FRANCO
.X	± 0.20	-	CHECKED
.XX	± 0.20	-	CHRIS
UNLESS OTHERWISE SPECIFIED			
ANGULAR DIMENSIONS	THIRD ANGLE PROJECTION	APPROVED	CHRIS
SCALE	UNIT	SIZE	A3
1:1	MM		

A

TITLE			
TITLE	MATERIAL	FINISH	CUS. PART NO.
COOLER ASSEMBLY			M20816-001
			CUS. PART NO.

A

PART INFO			
PART NO.	REV.	SHEET	DATE
JSC00123	A	1 OF 8	2021-07-19

A

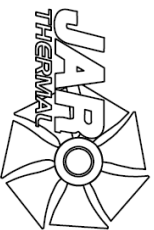

2. Exploded views

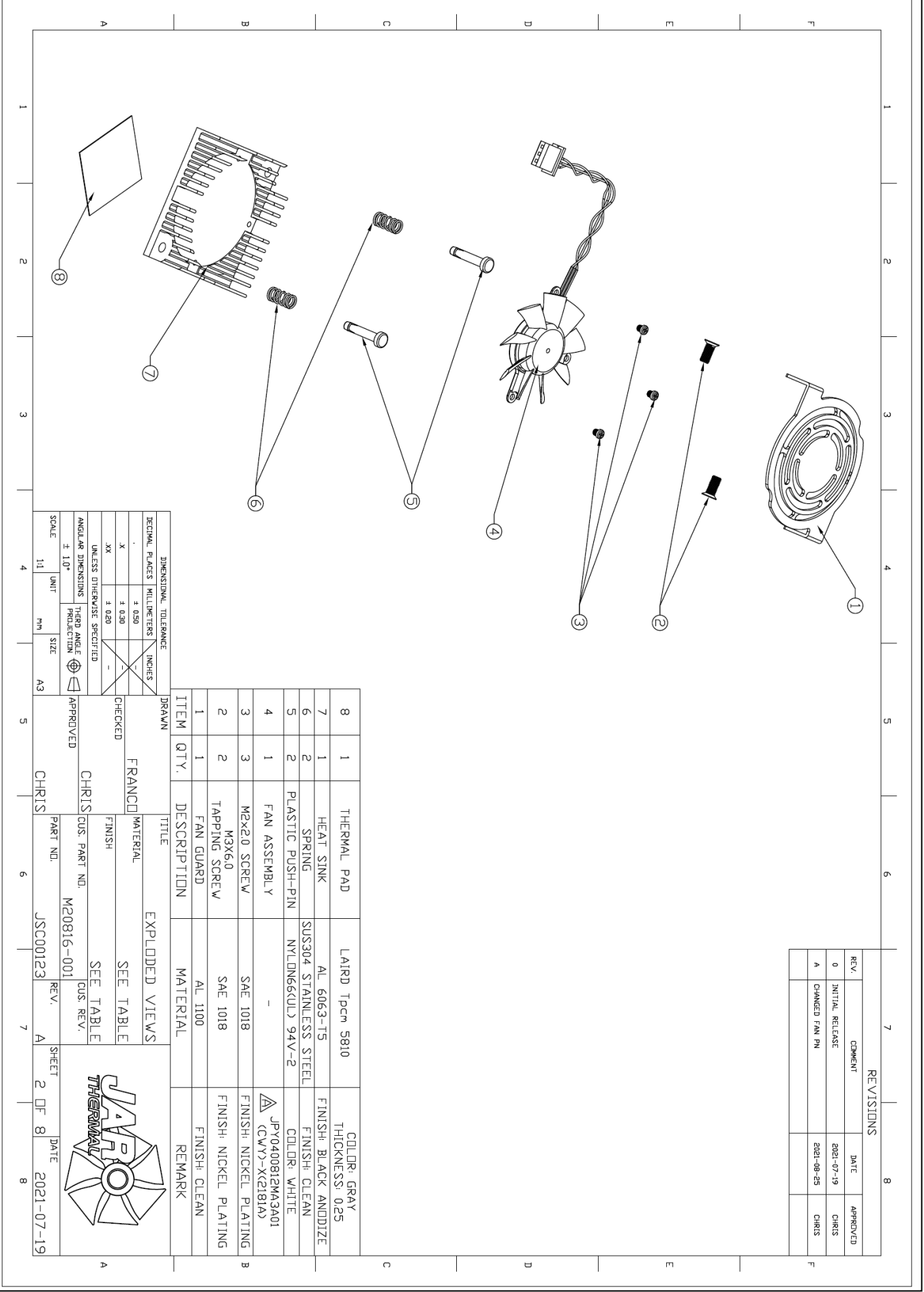

REVISIONS			
REV.	COMMENT	DATE	APPROVED
0	INITIAL RELEASE	2021-07-19	CHRIS
A	CHANGED FAN PIN	2021-08-25	CHRIS

ITEM	QTY.	DESCRIPTION	MATERIAL	REMARK
8	1	THERMAL PAD	LAIRD Tpcm 5810	COLOR: GRAY THICKNESS: 0.25
7	1	HEAT SINK	AL 6063-T5	FINISH: BLACK ANODIZE
6	2	SPRING	SUS304 STAINLESS STEEL	FINISH: CLEAN
5	2	PLASTIC PUSH-PIN	NYLON66(UL) 94V-2	COLOR: WHITE
4	1	FAN ASSEMBLY	-	△JPY0400812MA3A01 (CWYY-XE2181A)
3	3	M2x2.0 SCREW	SAE 1018	FINISH: NICKEL PLATING
2	2	TAPPING SCREW	SAE 1018	FINISH: NICKEL PLATING
1	1	FAN GUARD	AL 1100	FINISH: CLEAN

DIMENSIONAL TOLERANCE DECIMAL PLACES MILLIMETERS INCHES .X ± 0.50 ± 0.020 .XX ± 0.25 ± 0.010 UNLESS OTHERWISE SPECIFIED ANGLE DIMENSIONS THIRD ANGLE PROJECTION SCALE ± 1.0x		CHECKED FRANCQ FINISH APPROVED CHRIS		TITLE EXPLODED VIEWS MATERIAL SEE TABLE CUS. PART NO. M20816-001		PART NO. JSC00123 REV. A		SHEET 2 OF 8 DATE 2021-07-19	
--	--	--	--	---	--	-----------------------------------	--	---------------------------------------	--

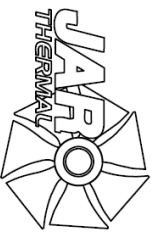

3. Individual component drawing

1) Heat sink

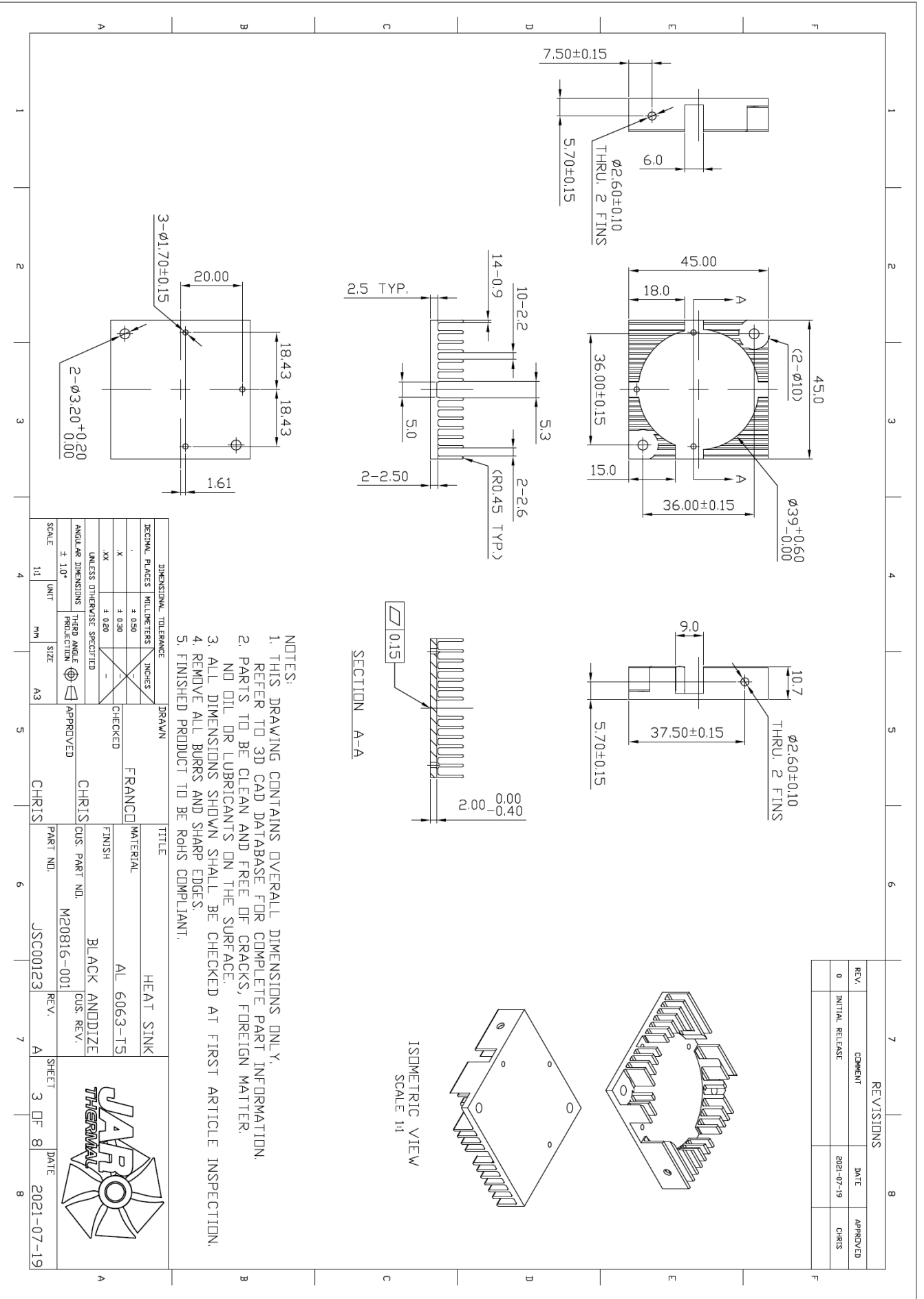

- NOTES:
1. THIS DRAWING CONTAINS OVERALL DIMENSIONS ONLY. REFER TO 3D CAD DATABASE FOR COMPLETE PART INFORMATION.
 2. PARTS TO BE CLEAN AND FREE OF CRACKS, FOREIGN MATTER, NO OIL OR LUBRICANTS ON THE SURFACE.
 3. ALL DIMENSIONS SHOWN SHALL BE CHECKED AT FIRST ARTICLE INSPECTION.
 4. REMOVE ALL BURRS AND SHARP EDGES.
 5. FINISHED PRODUCT TO BE ROHS COMPLIANT.

DIMENSIONAL TOLERANCE		DRAWN		TITLE	
DECIMAL PLACES	MILLIMETERS	INCHES	CHECKED	MATERIAL	HEAT SINK
.	± 0.50	± 0.020	FRANCO	AL 6063-T5	
XX	± 0.20			FINISH	BLACK ANODIZE
UNLESS OTHERWISE SPECIFIED			APPROVED	CUS. PART NO.	M20816-001
ANGULAR DIMENSIONS			THIRD ANGLE PROJECTION	REV.	JSC00123
SCALE	1:1	UNIT	mm	SIZE	A3

REVISIONS			
REV.	COMMENT	DATE	APPROVED
0	INITIAL RELEASE	2021-07-19	CHRIS

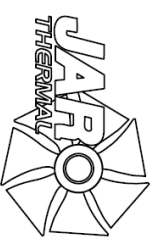

2) Fan guard

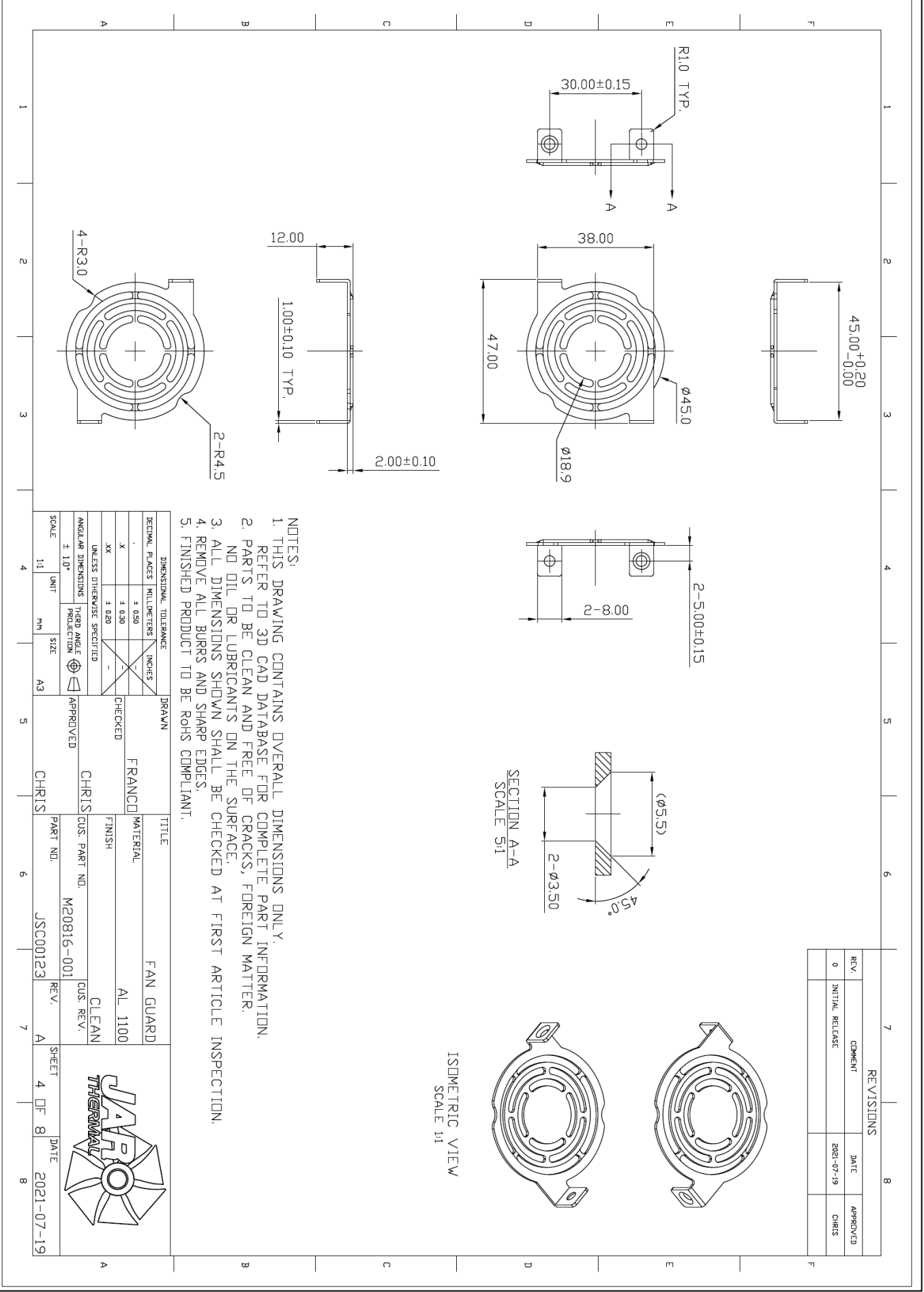

REVISIONS			
REV.	COMMENT	DATE	APPROVED
0	INITIAL RELEASE	2021-07-19	CHRIS

DIMENSIONAL TOLERANCE		DRAWN		TITLE	
SCALE	1:1	UNIT	mm	SIZE	A3
DECIMAL PLACES	MILLIMETERS	INCHES			
.X	± 0.50	-			
.XX	± 0.20	-			
UNLESS OTHERWISE SPECIFIED		CHECKED		FRANCO	
ANGULAR DIMENSIONS		APPROVED		CHRIS	
THIRD ANGLE PROJECTION		MATERIAL		AL-1100	
		FINISH		CLEAN	
		CUS. PART NO.		M20816-001	
		PART NO.		JSC00123	
		REV.		A	
		SHEET		4 OF 8	
		DATE		2021-07-19	

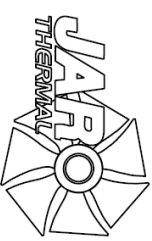

3) M3x6.0 Tapping screw

REVISIONS			
REV.	COMMENT	DATE	APPROVED
0	INITIAL RELEASE	2021-07-19	CHRIS

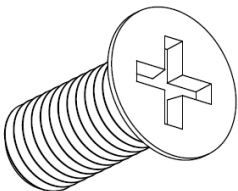
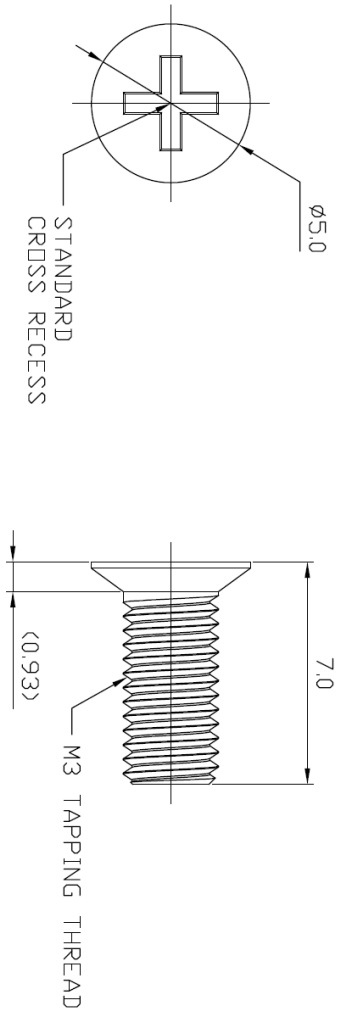

ISOMETRIC VIEW
SCALE 5:1

- NOTES:
1. MATERIAL: SAE 1018 ; FINISH: NICKEL PLATING
 2. THIS DRAWING CONTAINS OVERALL DIMENSIONS ONLY. REFER TO 3D CAD DATABASE FOR COMPLETE PART INFORMATION.
 3. PARTS TO BE CLEAN AND FREE OF CRACKS, FOREIGN MATTER. NO OIL OR LUBRICANTS ON THE SURFACE.
 4. ALL DIMENSIONS SHOWN SHALL BE CHECKED AT FIRST ARTICLE INSPECTION.
 5. REMOVE ALL BURRS AND SHARP EDGES.
 6. FINISHED PRODUCT TO BE ROHS COMPLIANT.

DIMENSIONAL TOLERANCE		DRAWN		TITLE	
DECIMAL PLACES	MILLIMETERS	INCHES	FRANCO	MATERIAL	M3x6.0 TAPPING SCREW
.	± 0.50	-	CHECKED	FINISH	SEE NOTES
X	± 0.30	-		CUS. PART NO.	M20816-001
XX	± 0.20	-		SEE NOTES	CUS. REV.
UNLESS OTHERWISE SPECIFIED			CHRIS		
ANGULAR DIMENSIONS			APPROVED		
± 1.0°			THIRD ANGLE PROJECTION		
SCALE	5:1	UNIT	mm	SIZE	A4

DRAWN		CHECKED		APPROVED	
FRANCO	CHRIS	CHRIS	CHRIS	PART NO.	JSC00123
REV.	A	SHEET	5 OF 8	DATE	2021-07-19

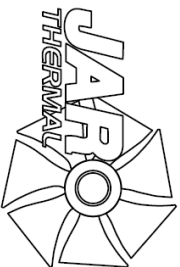

4) M2x2.0 Screw

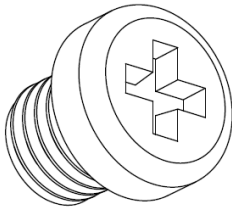
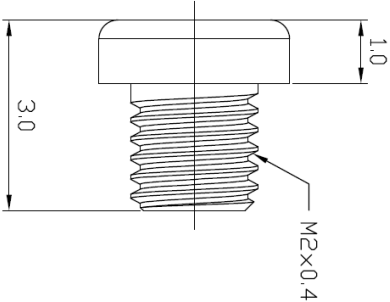
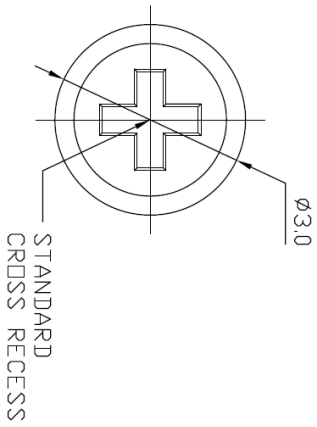

ISOMETRIC VIEW
SCALE 10:1

REVISIONS			
REV.	COMMENT	DATE	APPROVED
0	INITIAL RELEASE	2021-07-19	CHRIS

- NOTES:
1. MATERIAL: SAE 1018 ; FINISH: NICKEL PLATING
 2. THIS DRAWING CONTAINS OVERALL DIMENSIONS ONLY. REFER TO 3D CAD DATABASE FOR COMPLETE PART INFORMATION.
 3. PARTS TO BE CLEAN AND FREE OF CRACKS, FOREIGN MATTER. NO OIL OR LUBRICANTS ON THE SURFACE.
 4. ALL DIMENSIONS SHOWN SHALL BE CHECKED AT FIRST ARTICLE INSPECTION.
 5. REMOVE ALL BURRS AND SHARP EDGES.
 6. FINISHED PRODUCT TO BE ROHS COMPLIANT.

DIMENSIONAL TOLERANCE		DRAWN		TITLE	
DECIMAL PLACES	MILLIMETERS	INCHES	FRANCO	MATERIAL	M2x2.0 SCREW
.	± 0.50	-	CHECKED	FINISH	SEE NOTES
X	± 0.30	-	CHRIS	CUS. PART NO.	M20816-001
XX	± 0.20	-		APPROVED	CUS. REV.
UNLESS OTHERWISE SPECIFIED			SEE NOTES		
ANGULAR DIMENSIONS					
$\pm 1.0^\circ$					
SCALE	10:1	UNIT	mm	SIZE	A4
PART NO.		JSC00123	REV.	A	SHEET
DATE		2021-07-19	6 OF 8		DATE

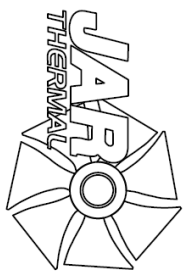

5) Plastic push-pin assembly

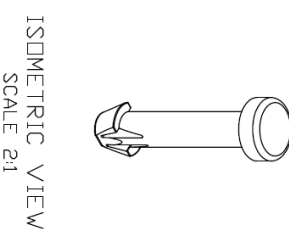
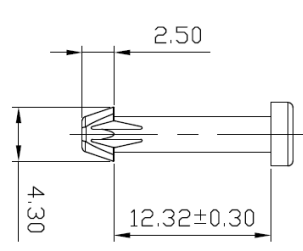
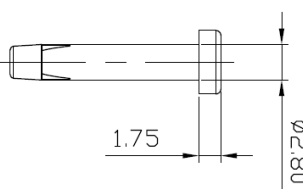
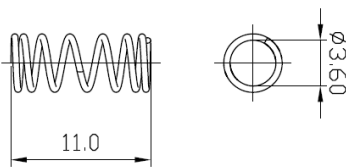
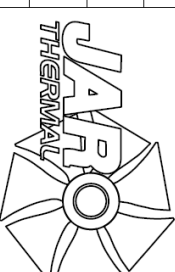
<p style="text-align: center;">ISOMETRIC VIEW SCALE 2:1</p> 	<p style="text-align: center;">ISOMETRIC VIEW SCALE 2:1</p> 	<p style="text-align: center;">ISOMETRIC VIEW SCALE 2:1</p> 	<p style="text-align: center;">ISOMETRIC VIEW SCALE 2:1</p> 																				
<p>NOTES FOR PLASTIC PUSH-PIN (HSR-30):</p> <ol style="list-style-type: none"> MATERIAL: NYLON66(GUL) 94V-2 COLOR: WHITE THIS DRAWING CONTAINS OVERALL DIMENSIONS ONLY, REFER TO 3D CAD DATABASE FOR COMPLETE PART INFORMATION. ALL DIMENSIONS SHOWN SHALL BE CHECKED AT FIRST ARTICLE INSPECTION. REMOVE ALL BURRS AND SHARP EDGES. FINISHED PRODUCT TO BE ROHS COMPLIANT. <p>SUGGESTION FOR PCB HOLE SIZE:</p> <ol style="list-style-type: none"> DRILL SIZE: Ø3.0mm ANNUAL RING: Ø6.0mm 	<p>NOTES FOR SPRING:</p> <ol style="list-style-type: none"> FREE LENGTH: 11.0mm WIRE DIAMETER: 0.50±0.05mm OD: Ø4.60mm ACTIVE COILS: 5 ; TOTAL COILS: 7 SPRING RATE: 0.1655 kgf/mm ± 10% MATERIAL: SUS304 STAINLESS STEEL FINISH: CLEAN ALL DIMENSIONS SHOWN SHALL BE CHECKED AT FIRST ARTICLE INSPECTION. FINISHED PRODUCT TO BE ROHS COMPLIANT. 																						
<p style="text-align: center;">DIMENSIONAL TOLERANCE</p> <table border="1" style="width: 100%; border-collapse: collapse;"> <thead> <tr> <th>DECIMAL PLACES</th> <th>MILLIMETERS</th> <th>INCHES</th> </tr> </thead> <tbody> <tr> <td>0</td> <td>± 0.50</td> <td>-</td> </tr> <tr> <td>1</td> <td>± 0.30</td> <td>-</td> </tr> <tr> <td>2</td> <td>± 0.20</td> <td>-</td> </tr> </tbody> </table> <p>UNLESS OTHERWISE SPECIFIED</p>		DECIMAL PLACES	MILLIMETERS	INCHES	0	± 0.50	-	1	± 0.30	-	2	± 0.20	-	<p style="text-align: center;">REVISIONS</p> <table border="1" style="width: 100%; border-collapse: collapse;"> <thead> <tr> <th>REV.</th> <th>COMMENT</th> <th>DATE</th> <th>APPROVED</th> </tr> </thead> <tbody> <tr> <td>0</td> <td>INITIAL RELEASE</td> <td>2021-07-19</td> <td>CHRIS</td> </tr> </tbody> </table>		REV.	COMMENT	DATE	APPROVED	0	INITIAL RELEASE	2021-07-19	CHRIS
DECIMAL PLACES	MILLIMETERS	INCHES																					
0	± 0.50	-																					
1	± 0.30	-																					
2	± 0.20	-																					
REV.	COMMENT	DATE	APPROVED																				
0	INITIAL RELEASE	2021-07-19	CHRIS																				
<p style="text-align: center;">DRAWN: FRANCISCO CHECKED: CHRIS APPROVED: CHRIS</p>		<p style="text-align: center;">TITLE: PLASTIC PUSH-PIN ASSY. MATERIAL: SEE NOTES FINISH: SEE NOTES CUS. PART NO.: M20816-001 CUS. REV.: PART NO.: JSC00123 REV.: A</p>																					
<p style="text-align: center;">SCALE: 2:1 UNIT: mm SIZE: A4</p>		<p style="text-align: center;">SHEET: 7 OF 8 DATE: 2021-07-19</p> 																					

6) Thermal pad

REVISIONS			
REV.	COMMENT	DATE	APPROVED
0	INITIAL RELEASE	2021-07-19	CHRIS

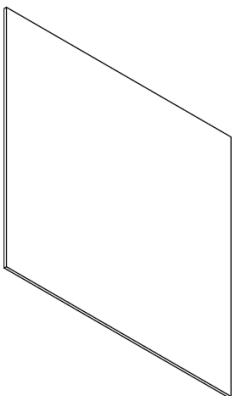
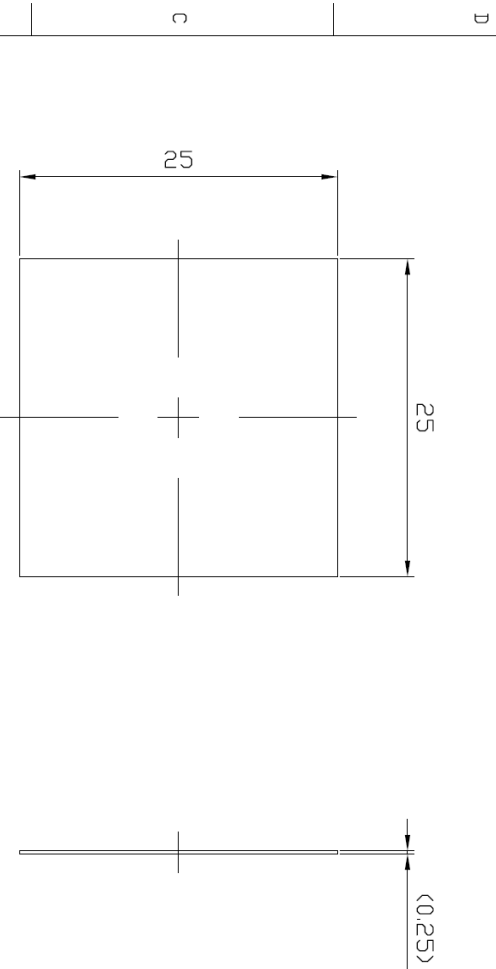

ISOMETRIC VIEW
SCALE 2:1

- NOTES:
1. THIS DRAWING CONTAINS OVERALL DIMENSIONS ONLY. REFER TO 3D CAD DATABASE FOR COMPLETE PART INFORMATION.
 2. ALL DIMENSIONS SHOWN SHALL BE CHECKED AT FIRST ARTICLE INSPECTION.
 3. FINISHED PRODUCT TO BE ROHS COMPLIANT.
 4. DO NOT USE THE PAD IN THE ENVIRONMENT WITH CORROSIVE AIR OR LIQUID. THE PAD MUST BE STORED AT ROOM TEMPERATURE CONDITION 22°C (FAHRENHEIT 71.6°F), AND 50% RH.

DIMENSIONAL TOLERANCE		DRAWN		TITLE	
DECIMAL PLACES	MILLIMETERS	INCHES	FRANCO	MATERIAL	THERMAL PAD
.	± 0.50	-	CHECKED	LAIRD Tpcm 5810	
.X	± 0.30	-		COLOR	GRAY
.XX	± 0.20	-		CUS. PART NO.	M20816-001
UNLESS OTHERWISE SPECIFIED			CHRIS	CUS. REV.	
ANGULAR DIMENSIONS			APPROVED		
± 1.0°			CHRIS		
THIRD ANGLE PROJECTION					
SCALE	2:1	UNIT	mm	SHEET	8 OF 8
		SIZE	A4	DATE	2021-07-19
			CHRIS		
			JSC00123		
			REV. A		

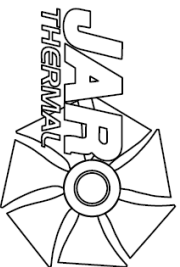



JARO THERMAL

SPECIFICATION FOR APPROVAL

Customer :
Customer Part No. :
Description : DC FAN
JARO Model No. : JPY0400812MA3A01(CWY)-X(2181A) REV.A
Sample Issue No. :
Sample Issue Date :
 Preliminary Specification
 Formal Specification

PREPARED BY :	Franco Huang	DATE :	09/10/2021
CHECKED BY :	Ivan Chen	DATE :	09/10/2021
APPROVED BY :	Jay Su	DATE :	09/10/2021

PLEASE SEND ONE COPY OF THIS SPECIFICATION BACK AFTER YOU SIGNED APPROVAL FOR PRODUCTION PRE-ARRANGEMENT.

By: _____ (printed)

Signature: _____

Date: _____



Jaro Thermal USA office
6600 Park of Commerce Blvd.
Boca Raton, Florida 33487
www.jarothermal.com
Ph: 561-241-6700
Fx: 561-241-3328

Jaro Thermal Taiwan office
Building H, No.119-1, Zhudong Rd., Renwu
Dist., Kaohsiung City, Taiwan 81448
www.jarothermal.com
Ph: +886-7-375-2053
Fx: +886-7-374-7403

We keep the world cool™



JARO SPEC NUMBER	
SPEC	2181A

Revision of Spec History

Revision	Change Content	Change page	DATE	BY
0	Created SPEC		08/21/2020	Caleb Huang
A	The IC changed to Prolific PT3923-A and updated JARO model name.	11~21	09/10/2021	Franco Huang

Notice:

1. This specification will be changed base on Jaro Thermal 's notification. Pls refer to update revision of spec by contacting Jaro Thermal.
2. This specification clarify all the mechanical & electrical characteristics of DC brushless fans & AC brushless fans & Heatsink.
3. The specification of this product is described in detailed document. Pls do not use the fan without proper usage. Pls contact Jaro Thermal if you have special requirement which is not listed on this specification.
4. Any of change, pls contact Jaro Thermal to change the new revision in order to make sure all technical data is up to date. Any ECN change will be followed by sending new update spec.



SPECIFICATION



Jaro Model : JPY0400812MA3A01(CWY)-X(2181A)

Samples attached : pcs

Safety Approval : CE

FEATURES

<input checked="" type="checkbox"/>	FG SIGNAL	<input type="checkbox"/>	IP-55 RATED
<input type="checkbox"/>	RD SIGNAL	<input checked="" type="checkbox"/>	HIGH TEMP RATED
<input type="checkbox"/>	PWM	<input type="checkbox"/>	3-PHASE MOTOR

DIMENSIONS	:	40	X	40	X	08	mm
BEARING TYPE	:	AFB					
MOTOR PROTECTION	:	BY	IC				
RATED VOLTAGE	:	12.0	VDC				
OPERATING VOLTAGE RANGE	:	10.8	~	13.2	VDC		
START-UP VOLTAGE	:	9.0	VDC , (POWER ON/OFF)				
REAL CURRENT	:	0.08	Amp				
REAL POWER	:	0.96	Watt				
RATED CURRENT	:	0.10	Amp (MAX: 0.11Amp)				
RATED POWER	:	1.20	Watt				
RATED SPEED	:	5000	RPM		± 20 %		
		(IN FREE AIR AT RATED VOLTAGE)					
AIR FLOW	:	7.12	CFM		(min.: 5.696 CFM)		
AIR FLOW	:	0.201	CMM		(min.: 0.160 CMM)		
		(IN FREE AIR AT RATED VOLTAGE)					
STATIC AIR PRESSURE	:	0.090	InH2O		(min.: 0.057 InH2O)		
STATIC AIR PRESSURE	:	2.31	mmH2O		(min.: 1.478 mmH2O)		
		(IN FREE AIR AT RATED VOLTAGE)					
NOISE LEVEL	:	26.0	dB(A)		(MAX.: 30.0 dB(A))		
LIFE EXPECTANCY	:	50000	Hours		at 40°C / 65% RH		
NET WEIGHT	:	5	Gram				



The standard of Jaro Thermal's fan relative humidity is 65%, and the temperature is 25°C for the standard testing. If you have any question, pls refer to environmental condition on 5-0 first. Other special request pls contact Jaro Thermal for spec checking.



SPECIFICATION

JARO MODEL: JPY0400812MA3A01(CWY)-X(2181A)

1-0 MATERIAL

- 1-1 Bracket Material - PBT 94V-0 (Black)
- 1-2 Fan Blade Material - PBT 94V-0 (Black)
- 1-3 Other material – See 8.0 Dimension Drawing
- 1-4 Environmental Standard
 - [V] RoHS
 - [V] REACH
 - [] Halogen Free

2-0 FAN VOLTAGE CURRENT, LOCK ROTOR, AIR FLOW, STATIC PRESSURE & NOISE DEFINITION

- 2-1 Start Voltage - By sudden switching ON fan is start to rotate.
- 2-2 Input Power - Input Power shall be measured after 3 minutes for continuing rotation by rated voltage.
- 2-3 Rated Current - Rated Current shall be measured after 3 minutes by continuing rotation by rated voltage.
- 2-4 Rated Speed - Rated Speed shall be measured after 3 minutes for continuing rotation by rated voltage.
- 2-5 Locked Rotor Current : Locked current shall be measured within one minute of rotor locked, after 3 minutes by continuing rotation at rated voltage in clean air.
- 2-6 Air Flow & Static Pressure : The air flow data and static pressures should be determined in accordance with AMCA-210 standard or DIN24163 specification in chamber testing and record the test record.
- 2-7 Noise Level : The measurement of noise level is carried out with reference to CNS8753 in an anechoic chamber with the microphone positioned 1 meter from the air intake. Testing fan shall be hung in clean air .

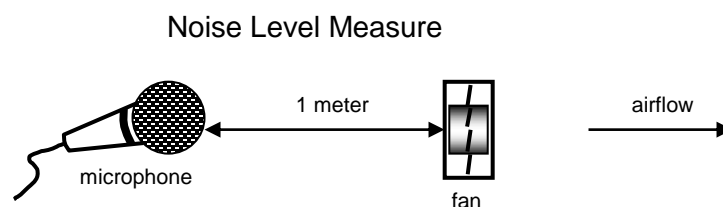



SPECIFICATION

JARO MODEL: JPY0400812MA3A01(CWY)-X(2181A)

3-0 FAN FUNCTION DEFINITION

- 3-1 Rotation Direction - Clockwise from impeller side.
- 3-2 Lock Rotor Condition
No damage for winding or electronic in locked rotor condition. And no damage after 72hrs continuing for lock rotor condition.
- 3-3 Auto Restart
Fan will automatic restart without any abnormal usage.
- 3-4 Dead Angle
Switch the fan change from off to on condition. Restart the fan, it will automatic restart by fan power on.
- 3-5 Polarity
Check the voltage and polarity before turn on the power to the fan.
- 3-6 Insulation Resistance
Do not use < 10M ohm between housing and positive end of lead wire (red) at 500V DC.
- 3-7 Dielectric Strength
No damage should be found at 500 VAC for 60 seconds, measured with 1mA trip current between housing and positive end of lead wire.

4-0 FAN PACKAGE TEST

- 4-1 Free Drop Shock
Base on Jaro Thermal's standard package, the fan package will test and drops on any three faces - Test standard is 30cm height. The base is wood board for 10mm thick.

5-0 FAN ENVIRONMENTAL CONDITION

- 5-1 Operating Temperature / Humidity
-10°C to +85°C at humidity 5% to 90% Relative humidity.
- 5-2 Humidity
After 96 hours, 95% RH, 40+/-2°C per MIL-STD-202F, method 103B humidity test, the measured data on insulation resistance and dielectric strength shall meet the specification.
- 5-3 Storage Temperature
All function shall be normal after 500 hours storage at -40°C to +85 °C with a 24 hour recovery period at room temperature. Humidity 5% to 95% Relative humidity
- 5-4 Do not store this fan in an environment with high humidity. This fan must be stored in accordance with the storage temperature. Do not store the fan for over 6 months; If this fan is stored for more than 6 months, JARO THERMAL recommends functional testing before using.



SPECIFICATION

JARO MODEL: JPY0400812MA3A01(CWY)-X(2181A)

5-5 Improper way to disassembled fan will cause the fan get into dust or dip into water. Which will in defects is not covered in the warranty. Do not use the fan in the environment with corrosive air or liquid.

6-0 MASS PRODUCTION SAMPLE PLAN INSPECTION

All fans shall meet the quality inspection under MIL-STD-105E standard list as follow:

Critical 0.25%

Major 1.00%

Minor 2.50%

7-0 FAN USE WITH CAUTION

7-1 Please do not stick a grease and/or an oil to the fan housing or blade which may have a harmful influence by a chemical reaction at high humidity.

7-2 If the fan is reinstalled, please pay special attention to the noise due to the vibration (or resonance).

7-3 During the testing of the fan, please make sure the finger guard is use for your safety.

7-4 While the fan is running, please do not lock the fan intentionally for a long time. This will cause overheating by long period locking status. This action will damage the fan.

7-5 Please do not touch and push Fan Blade with fingers or others, fan blade and ball bearings may be damaged and it causes noise defect.

7-6 Do not carry the fan by its lead wires.

7-7 If the fan does not have the polarity protection function, the connection of the colored wires should be red + red, and black + black, or else the fan will be damaged in no time.

7-8 For the models without reverse connection of polarity protection, please do not connect the lead wire in reverse position.

7-9 Please don't install this fan in series with 2x voltage inputs. For example, if a single fan rated at 12V, then don't install two of them in series with 24V input.

7-10 Every specific fan is designed for its certain application (project). Therefore, if you want to use this fan in other application (project), please inform JARO first so that we can confirm whether there is any issue which might be incurred from the reason of this different application (project) or not.

7-11 The "Life Expectancy" of this fan has not been evaluated for use in combination with any end application. Therefore, the Life Expectancy in the Test Reports(L10 and MTTF Report) that relate to this fan is for reference only and shall not construe any kind of warranty of JARO to the life of any specific fan , either expressed or implied.

7-12 The period of product warranty , unless otherwise agreed by JARO in written , shall be 12 months staring from the date of production.



DIMENSION DRAWING

JARO MODEL: JPY0400812MA3A01(CWY)-X(2181A)

8-0 DIMENSIONS

All dimensions, Direction of rotation and air flow were specified as per drawing attached.

Description: DC Fan with:

Lead Wire: UL3302 , AWG#30 , 140 ± 10 mm lead length.

Housing: JST XHP-3

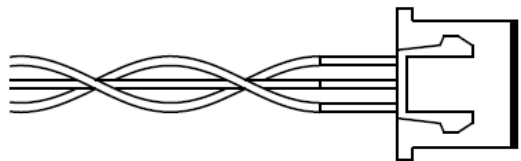
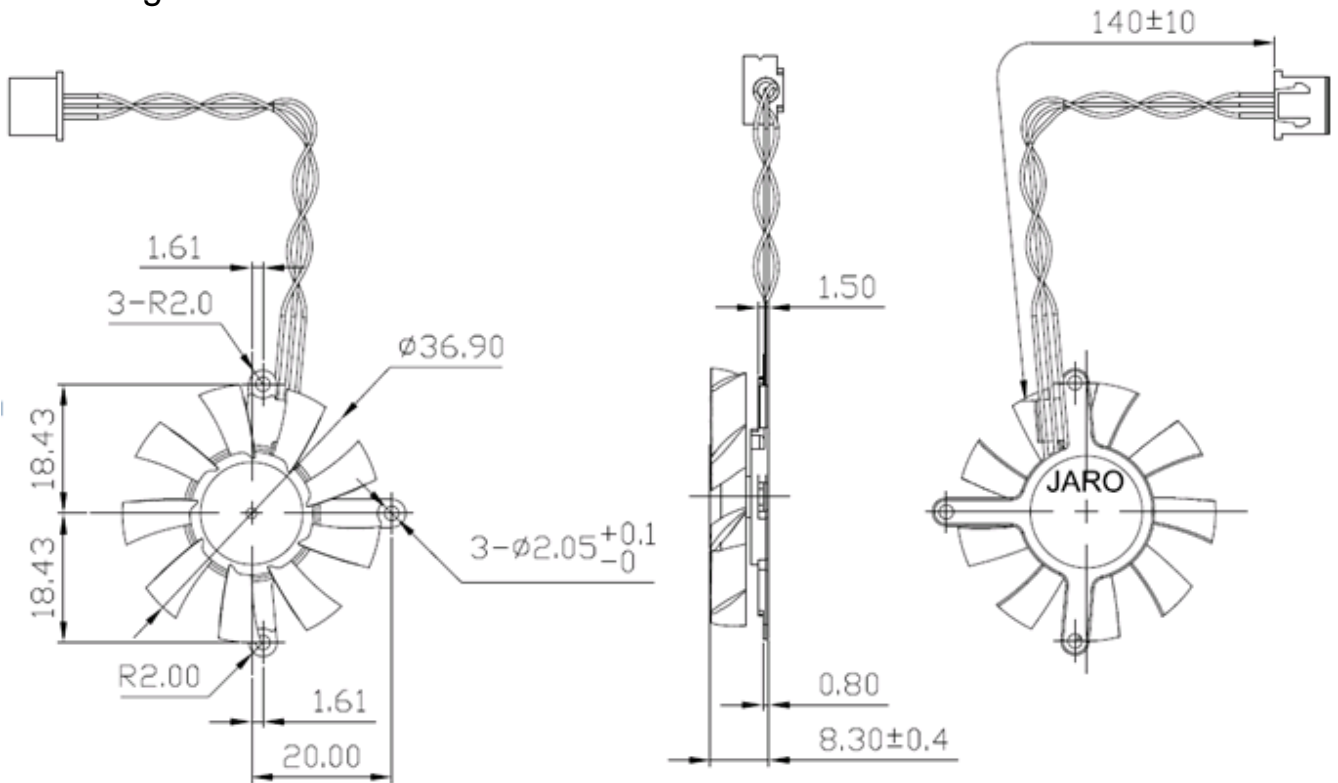

PIN1:BLACK WIRE----- (-)
PIN2:RED WIRE----- (+)
PIN3:YELLOW WIRE----- (FG)

DIAGRAM OF DIMENSIONS: Dimensions in millimeters
NOT TO SCALE. ALL COMPONENTS MUST BE RoHS/REACH COMPLIANT.

Drawing Note: N/A

Safety :CE



PERFORMANCE CURVE

JARO MODEL: JPY0400812MA3A01(CWY)-X(2181A)

9-0 PERFORMANCE CURVE

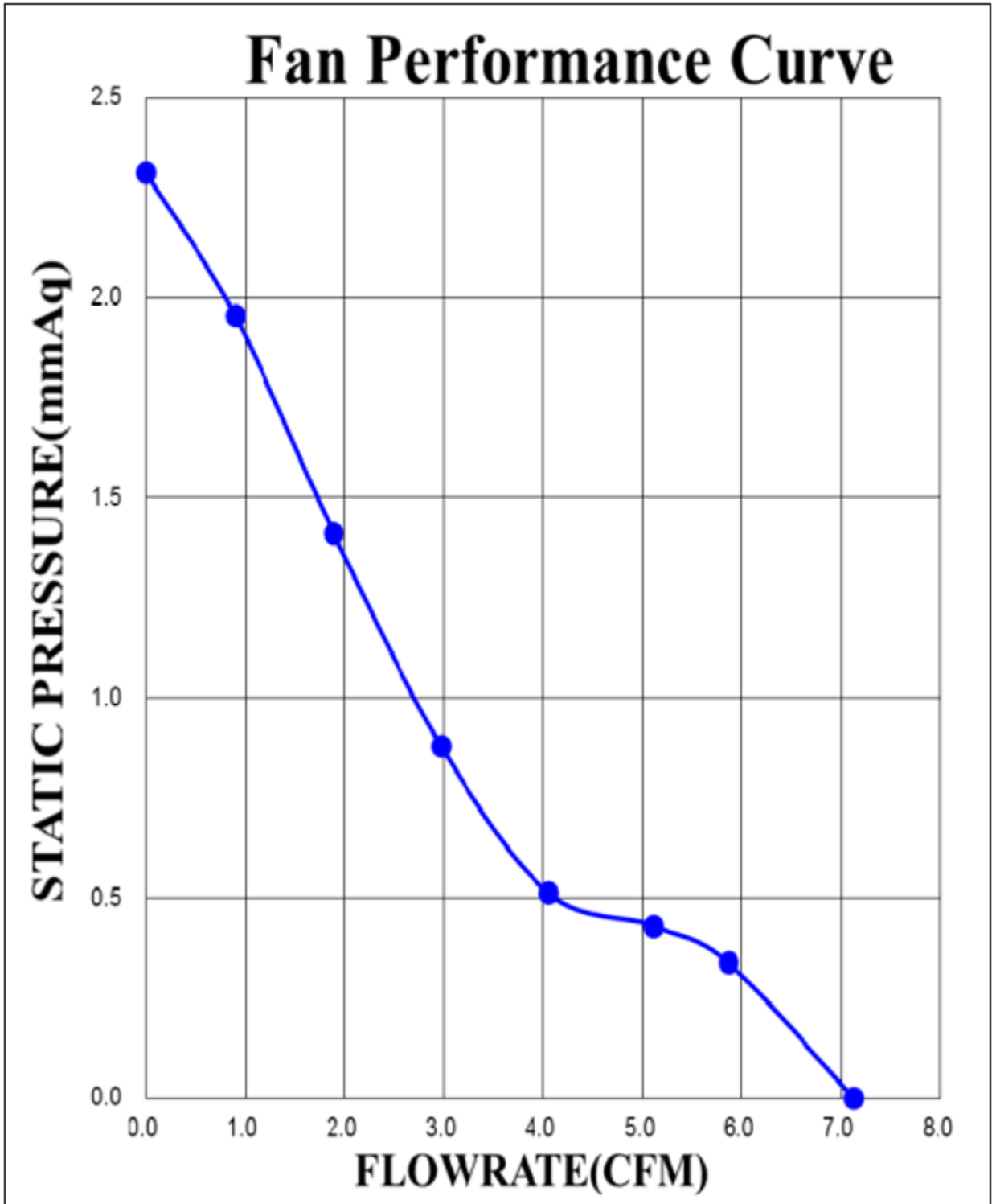



LIFE EXPECTANCY

JARO MODEL: JPY0400812MA3A01(CWY)-X(2181A)

10-0 LIFE EXPECTANCY

故障定義 Product Specification & Failure Definiton	試驗結果：包含故障時間、數據、統計、...等 Test Result : Including Time Of Failure、Datum、Statistics、... ect.																		
1.風扇不轉 (Fan Not Work) 2.轉速超出規格30% (Speed Over 30% Origin) 3.電流超出規格30% (Current Over 30% Origin)	<ul style="list-style-type: none"> 溫度加速因子 $TEMP A.F = e^{(\Delta H / K) \times (\frac{1}{273+Tl} - \frac{1}{273+Th})}$ 總試驗時間 Total Test Time = 200000 HRS. 查表得 (MTTF By GEM Table) MTTF = 153620 HRS. 																		
1.性能測試時點 The Time Of Check Point Start : 0Hr, 500Hrs, 1000Hrs And Finished	<ul style="list-style-type: none"> 溫度 / TEMP. / MTTF / L10 <table border="1" data-bbox="682 733 1268 959"> <thead> <tr> <th>溫度 TEMP.</th> <th>信賴水準90% CONFIDENCE LEVEL</th> <th>L10</th> </tr> </thead> <tbody> <tr> <td>30 ℃</td> <td>1065201</td> <td>112126</td> </tr> <tr> <td>40 ℃</td> <td>536033</td> <td>56424</td> </tr> <tr> <td>50 ℃</td> <td>281461</td> <td>29627</td> </tr> <tr> <td>60 ℃</td> <td>153620</td> <td>16171</td> </tr> <tr> <td>70 ℃</td> <td>86858</td> <td>9143</td> </tr> </tbody> </table>	溫度 TEMP.	信賴水準90% CONFIDENCE LEVEL	L10	30 ℃	1065201	112126	40 ℃	536033	56424	50 ℃	281461	29627	60 ℃	153620	16171	70 ℃	86858	9143
溫度 TEMP.	信賴水準90% CONFIDENCE LEVEL	L10																	
30 ℃	1065201	112126																	
40 ℃	536033	56424																	
50 ℃	281461	29627																	
60 ℃	153620	16171																	
70 ℃	86858	9143																	
2. Herewith, we could assume as right on the basis of above test result. Besides, if the actual test time exceed the required, it comes out that those fans' L ₁₀ expectancy and MTTF are greater than the warrant. MTTF: Mean Time To Failures. It should be used in a non-requirable system setting. Now we show the MTTF in our life report, that's because we will not repair the failed fans during life experiment. MTBF: Mean Time Between Failures. It should be used in a repairable system setting. Basically, MTBF is equal to MTTF, they use same formula to work out a life data.																			

MTTF & L10 Curve

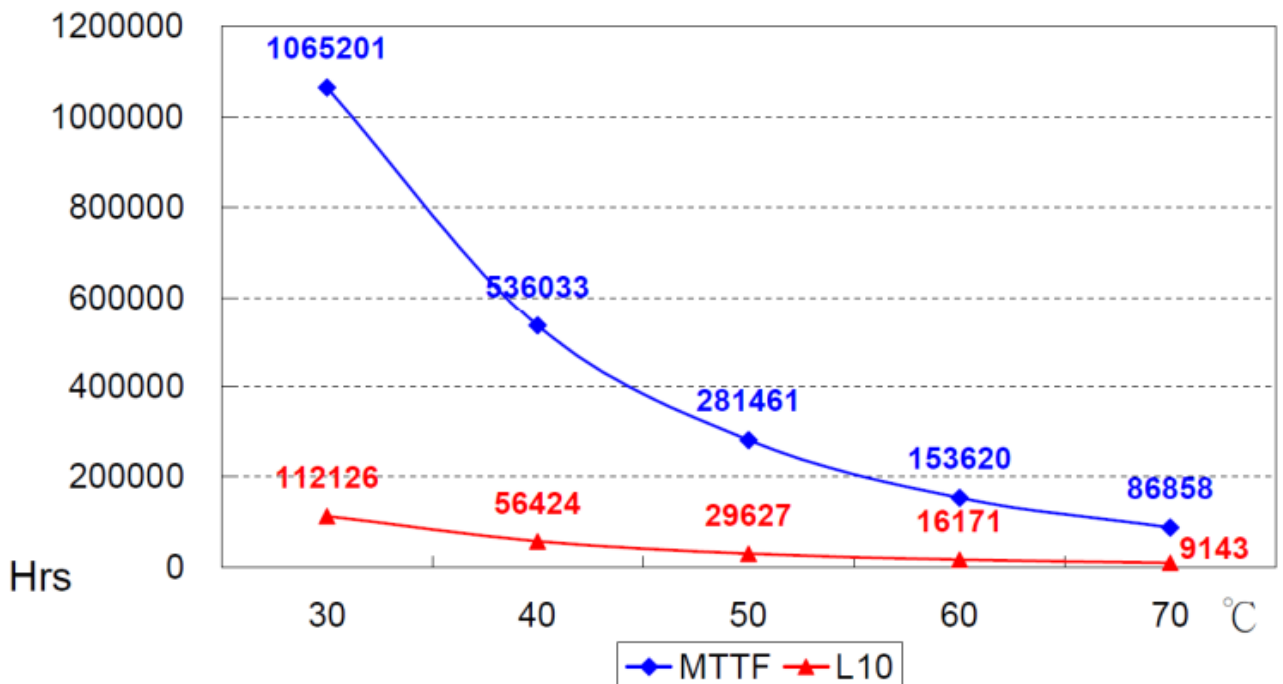

JARO MODEL: JPY0400812MA3A01(CWY)-X(2181A)

11-0 Lead Wire Design

Output method - open collector method:

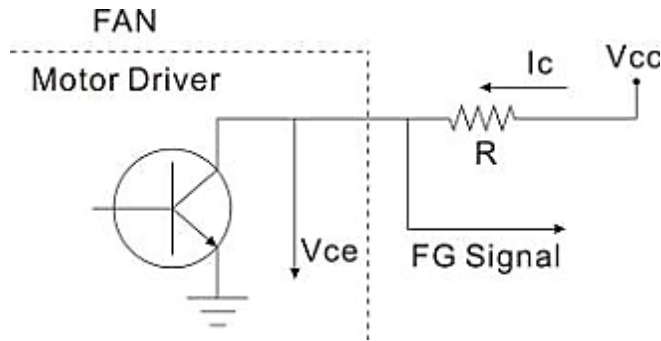

Circuit specification:

Specification

$$V_{cc} = 13.2V(\text{Max})$$

$$V_{ce}(\text{sat}) = 1.0V(\text{Max})$$

$$I_c = 5mA(\text{Max})$$

$$R \geq V_{cc}/I_c$$

Frequency Generator Waveform:

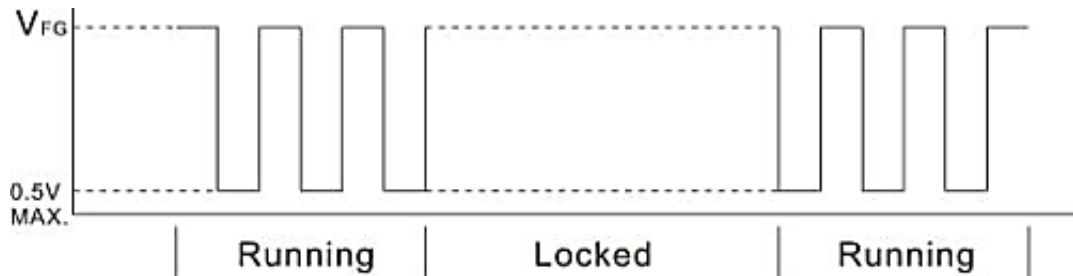

Fan Running for 2 pulse

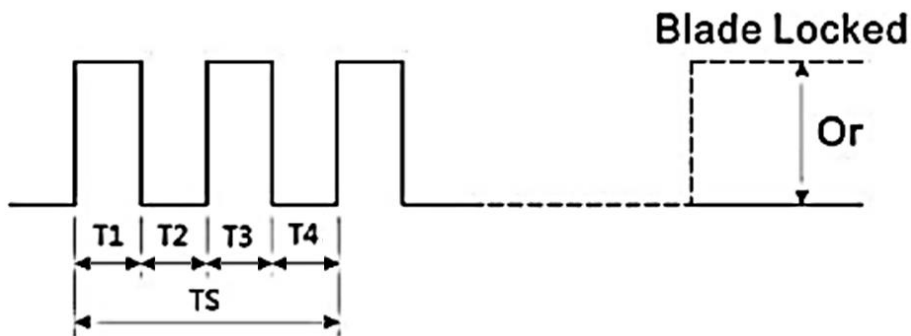

$$N = \text{R.P.M}$$

$$T1 = T2 = T3 = T4 = 1/4 TS$$

$$TS = 60/M \text{ (second)}$$

*2 Pulses for 1 rotation

JARO MODEL: JPY0400812MA3A01(CWY)-X(2181A)

NOTICE FOR OPERATION

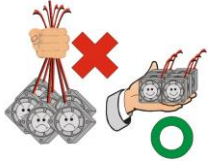

1



2

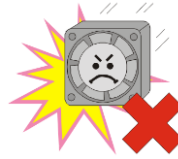

3



4

1. Hold the fan by frame side.
Do not hold lead wires.(Fig.1)
2. Do not touch or press on the impeller.
Do not crush the frame. (Fig.2)
3. Do not drop the fan on the ground.
Hit the frame may cause the fan damaged. (Fig.3)
4. Connect the power cord properly and apply voltage according to specification. (Fig.4)

NOTICE FOR ASSEMBLY AND AMBIENT CONDITIONS

1. When applying our fan your device, please check thoroughly any variation of EMC, temperature rise, life data, quality, etc. of this product by shock/drop/vibration testing, etc. If there is any problem or accident in connection with this product, it should be mutually discussed and checked by both parties.
2. Take proper care for handling this fan. Components such as fan holders or bearings may be damaged by fingers touch or other objects. Additionally, static electricity (ESD) may damage the internal circuits of the fan.
3. DO NOT operate this fan in proximity to hazardous materials such as organic silicon, cyanogen, formalin, phenol, or corrosive gas environments. Any hazardous materials flow to the fan side may cause damaged or malfunction.
4. JARO recommends that you protect this fan from exposure to outside elements such as dust, condensation, humidity or insects.
Exposure of this fan to outside elements such as dust, condensation, humidity or insects may affect its performance and may cause safety hazards. JARO does not guarantee the damage to the product caused by outside elements.
5. This fan must be installed properly and securely. Improper mounting may cause harsh resonance, vibration, and noise. If you have any question about fan mounting, please discuss with JARO if you are not sure the correct mounting method.
6. DO NOT use or store the fan with higher humidity and temperature specified in spec.
The fan must be stored with the attached specifications regarding storage temperature. If this fan is stored for more than 6 months, JARO recommends to perform functional testing before using. Please contact JARO if you are not sure how to perform functional test.
7. The "Life Expectancy" of this fan has not been evaluated for use in combination with any end application. Therefore, the Life Expectancy Test Reports (L10 and MTTF Report) that relate to this fan are only for reference.
8. Fan guards may prevent injury during handling or installation of the fan.