

REVISIONS			
REV.	COMMENT	DATE	APPROVED
0	INITIAL RELEASE	2023-09-07	CHRIS

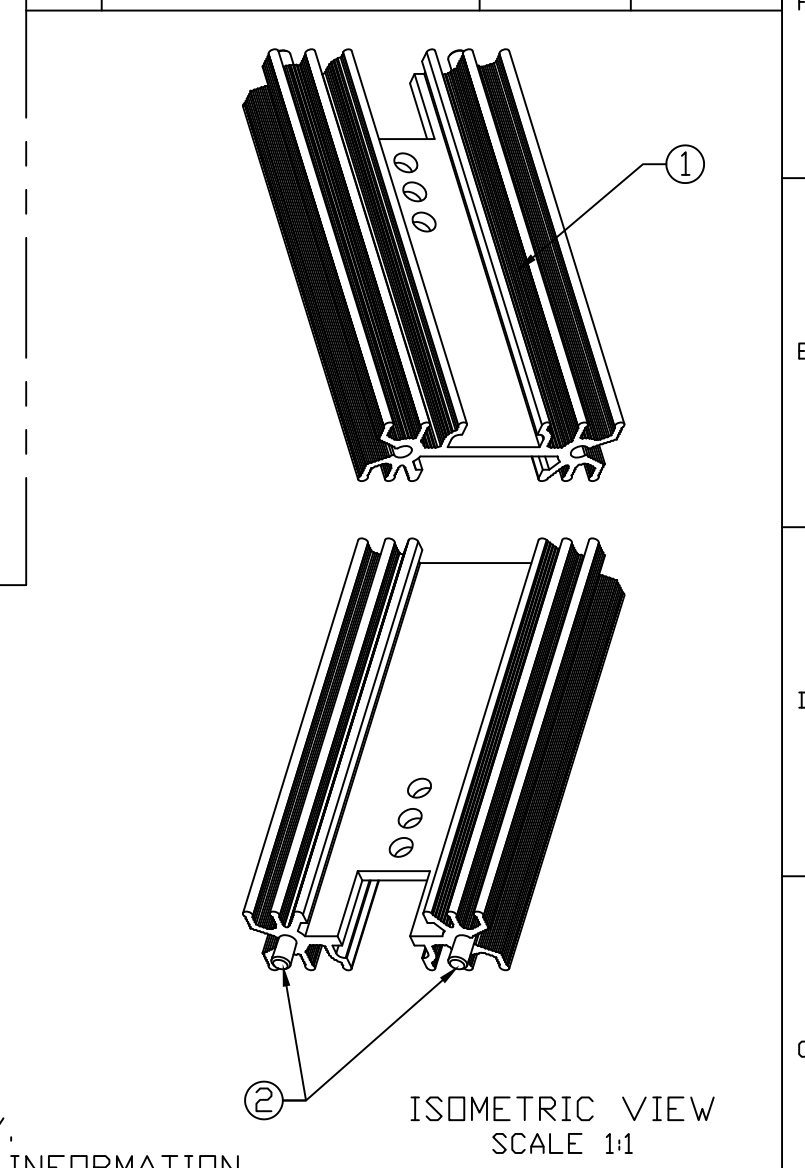

- NOTES:
1. THIS DRAWING CONTAINS OVERALL DIMENSIONS ONLY. REFER TO 3D CAD DATABASE FOR COMPLETE PART INFORMATION.
 2. PARTS TO BE CLEAN AND FREE OF CRACKS, FOREIGN MATTER. NO OIL OR LUBRICANTS ON THE SURFACE.
 3. ALL DIMENSIONS SHOWN SHALL BE CHECKED AT FIRST ARTICLE INSPECTION.
 4. REMOVE ALL BURRS AND SHARP EDGES.
 5. FINISHED PRODUCT TO BE RoHS COMPLIANT.
 6. TOLERANCE: $\pm 0.30\text{mm}$
 7. FOR CLIP: JBASS0421

DIMENSIONAL TOLERANCE			DRAWN	TITLE	MATERIAL	FINISH	CUS. PART NO.	CUS. REV.	PART NO.	REV.	SHEET	DATE
DECIMAL PLACES	MILLIMETERS	INCHES										
.X	-	-	SIDNEY	EXTRUDED PC MOUNT HEAT SINK	SEE TABLE	SEE TABLE	SEE TABLE	SEE TABLE	JBHAE2874	0	1 OF 1	2023-09-07
.XX	-	-										
UNLESS OTHERWISE SPECIFIED			CHECKED									
ANGULAR DIMENSIONS			APPROVED	CHRIS	SEE TABLE	SEE TABLE	SEE TABLE	SEE TABLE	SEE TABLE	SEE TABLE	SEE TABLE	SEE TABLE
$\pm 1.0^\circ$												
SCALE	UNIT	SIZE										
1:1	mm	A3										

