

1

2

3

4

5

6

REVISIONS

REV.	COMMENT	DATE	APPROVED
0	INITIAL RELEASE	2023-04-21	CHRIS

D

D

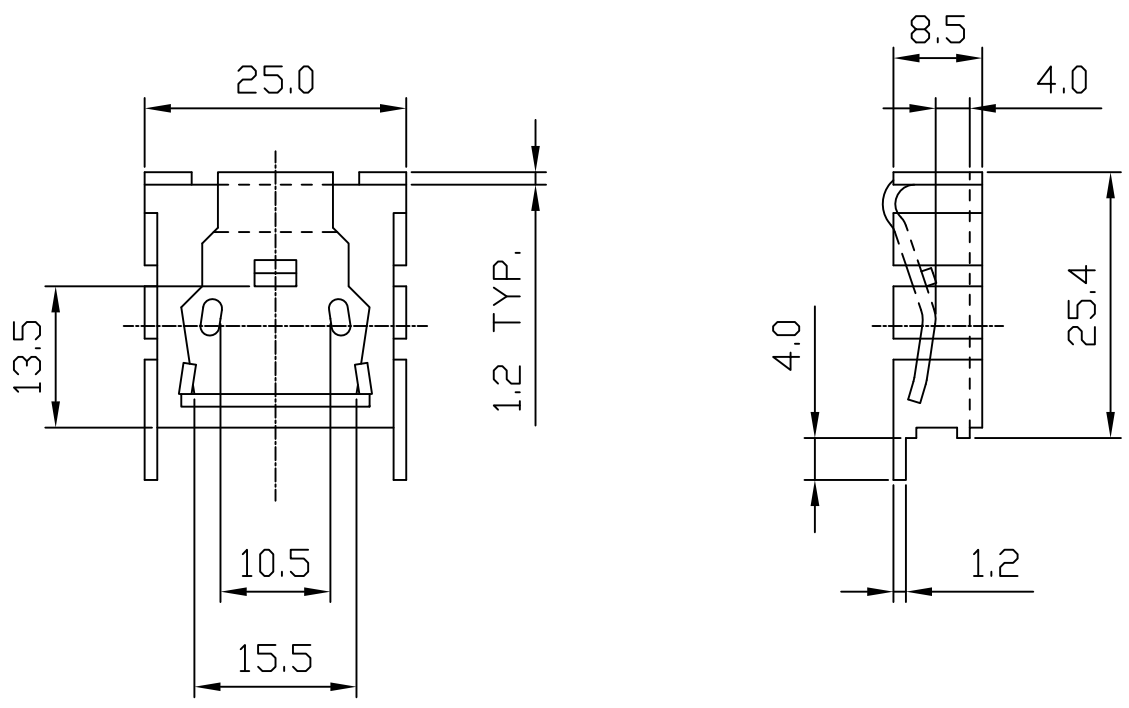

C

C

B

B

A

A

- NOTES:
1. THIS DRAWING CONTAINS OVERALL DIMENSIONS ONLY.  
REFER TO 3D CAD DATABASE FOR COMPLETE PART INFORMATION.
  2. PARTS TO BE CLEAN AND FREE OF CRACKS, FOREIGN MATTER.  
NO OIL OR LUBRICANTS ON THE SURFACE.
  3. ALL DIMENSIONS SHOWN SHALL BE CHECKED AT FIRST ARTICLE INSPECTION.
  4. REMOVE ALL BURRS AND SHARP EDGES.
  5. FINISHED PRODUCT TO BE RoHS COMPLIANT.
  6. TOLERANCE: ±0.50mm

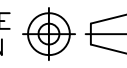
DIMENSIONAL TOLERANCE			DRAWN  SIDNEY	TITLE STAMPED HEAT SINK				
DECIMAL PLACES	MILLIMETERS	INCHES		CHECKED  CHRIS	MATERIAL AL 5052			
.	-	-			APPROVED  CHRIS		FINISH BLACK ANODIZE	
.X	-	-					CUS. PART NO.	CUS. REV.
.XX	-	-	UNLESS OTHERWISE SPECIFIED			PART NO. JBHAS2852    REV. 0    SHEET 1 OF 1    DATE 2023-04-21		
ANGULAR DIMENSIONS ± 1.0°		THIRD ANGLE PROJECTION						
SCALE	UNIT	SIZE	A4					

1

2

3

4

5

6