

1

2

3

4

5

6

REVISIONS

REV.	COMMENT	DATE	APPROVED
0	INITIAL RELEASE	2023-04-18	CHRIS

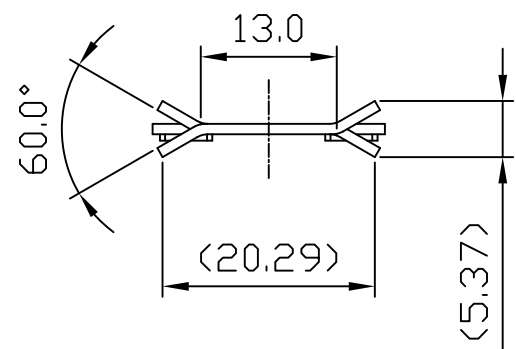

(5.37)

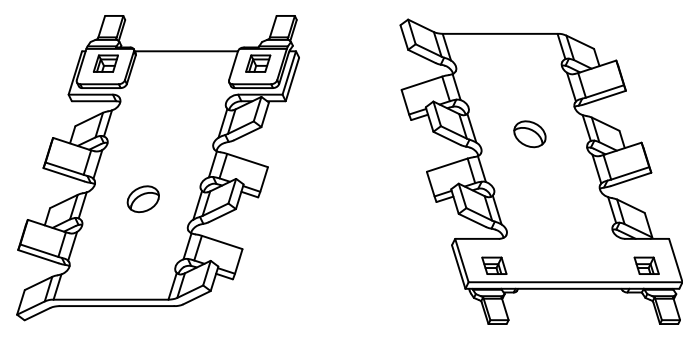
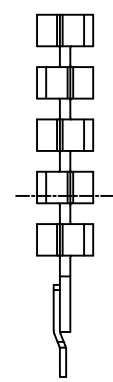
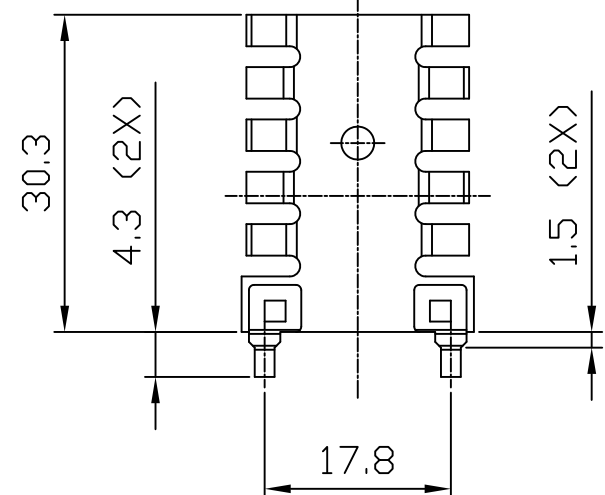
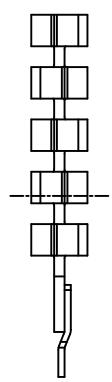

ISOMETRIC VIEW  
SCALE 1:1

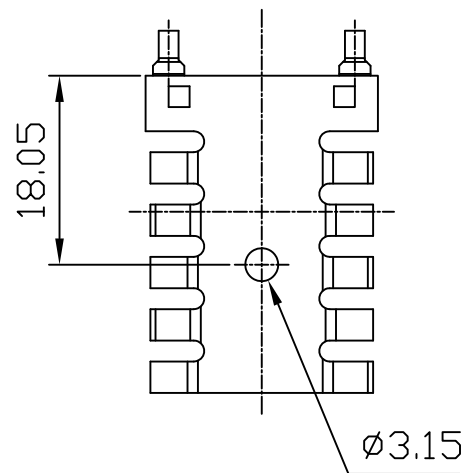
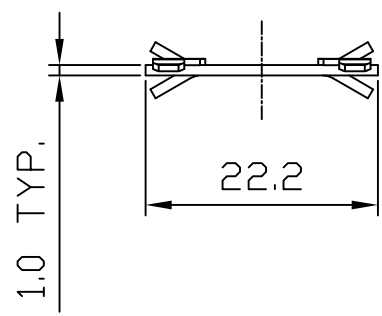

NOTES:

1. THIS DRAWING CONTAINS OVERALL DIMENSIONS ONLY. REFER TO 3D CAD DATABASE FOR COMPLETE PART INFORMATION.
2. PARTS TO BE CLEAN AND FREE OF CRACKS, FOREIGN MATTER. NO OIL OR LUBRICANTS ON THE SURFACE.
3. ALL DIMENSIONS SHOWN SHALL BE CHECKED AT FIRST ARTICLE INSPECTION.
4. REMOVE ALL BURRS AND SHARP EDGES.
5. FINISHED PRODUCT TO BE RoHS COMPLIANT.
6. TOLERANCE: ±0.50mm

DIMENSIONAL TOLERANCE			DRAWN SIDNEY	TITLE STAMPED HEAT SINK	
DECIMAL PLACES	MILLIMETERS	INCHES		MATERIAL AL 1050	
.	-	-	CHECKED CHRIS	FINISH BLACK ANODIZE	
.X	-	-		CUS. PART NO.	
.XX	-	-		CUS. REV.	
UNLESS OTHERWISE SPECIFIED			APPROVED CHRIS	PART NO.	REV.
ANGULAR DIMENSIONS ± 1.0°		THIRD ANGLE PROJECTION		JBHAS2631	0
SCALE	UNIT	SIZE	SHEET		DATE
1:1	mm	A4	1 OF 1		2023-04-18

