

REVISIONS			
REV.	COMMENT	DATE	APPROVED
0	INITIAL RELEASE	2023-07-04	CHRIS

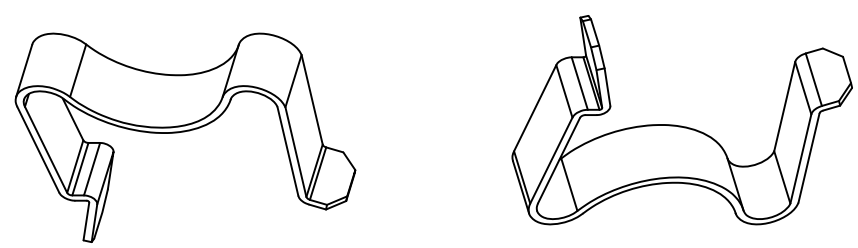

ISOMETRIC VIEW  
SCALE 2:1

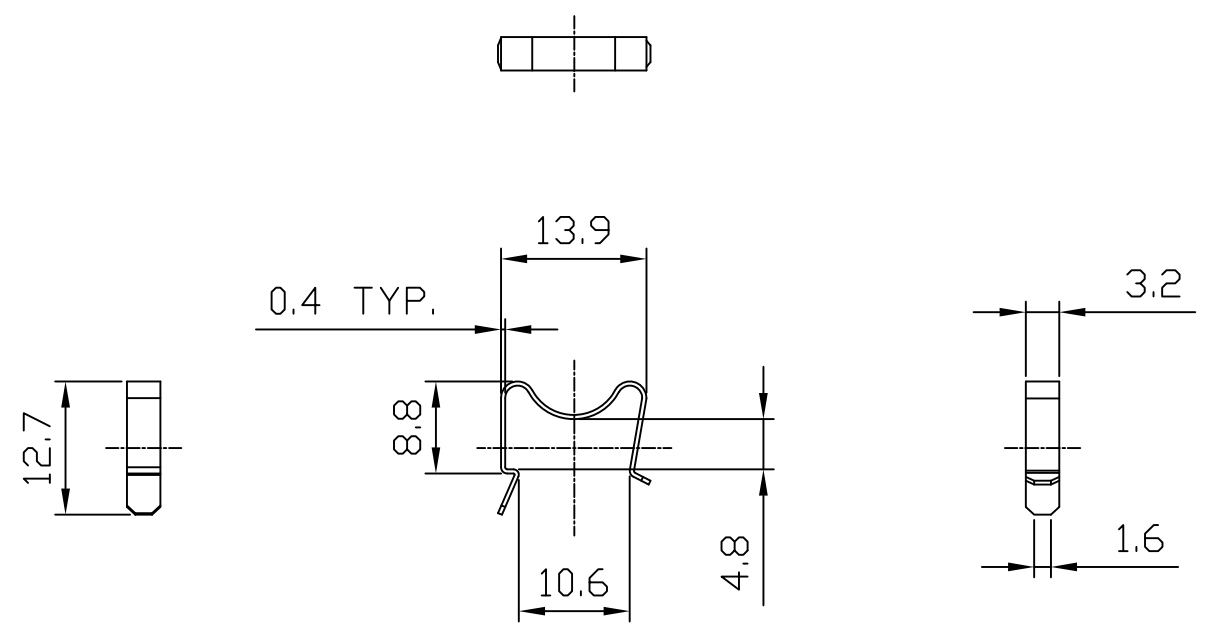
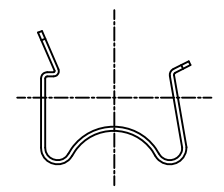
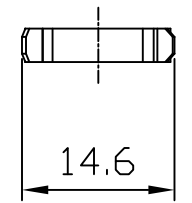

- NOTES:
- THIS DRAWING CONTAINS OVERALL DIMENSIONS ONLY. REFER TO 3D CAD DATABASE FOR COMPLETE PART INFORMATION.
  - PARTS TO BE CLEAN AND FREE OF CRACKS, FOREIGN MATTER. NO OIL OR LUBRICANTS ON THE SURFACE.
  - ALL DIMENSIONS SHOWN SHALL BE CHECKED AT FIRST ARTICLE INSPECTION.
  - REMOVE ALL BURRS AND SHARP EDGES.
  - FINISHED PRODUCT TO BE RoHS COMPLIANT.
  - TOLERANCE:  $\pm 0.50\text{mm}$
  - FOR STAMPED HEAT SINK: JBHAS0963

DIMENSIONAL TOLERANCE		
DECIMAL PLACES	MILLIMETERS	INCHES
.	-	-
.X	-	-
.XX	-	-
UNLESS OTHERWISE SPECIFIED		
ANGULAR DIMENSIONS	THIRD ANGLE PROJECTION	
$\pm 1.0^\circ$		
SCALE	UNIT	SIZE
1:1	mm	A4

DRAWN  
SIDNEY

CHECKED  
CHRIS

APPROVED  
CHRIS

TITLE  
CLIP

MATERIAL  
SUS 301

FINISH  
CLEAN

CUS. PART NO.      CUS. REV.

PART NO.      REV.      SHEET      DATE

JBASS0141      0      1 OF 1      2023-07-04

