

1

2

3

4

5

6

REVISIONS

REV.	COMMENT	DATE	APPROVED
0	INITIAL RELEASE	2023-06-08	CHRIS

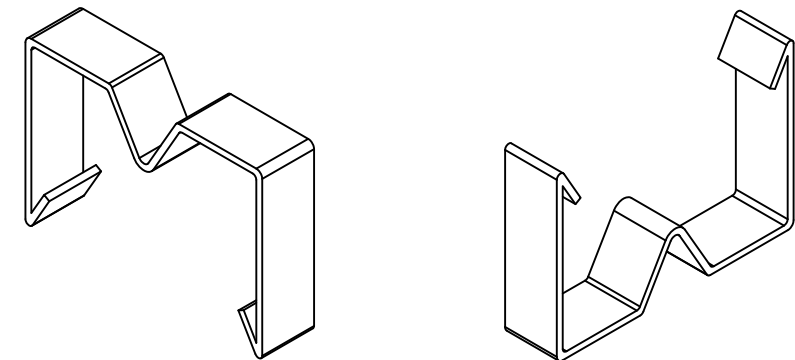
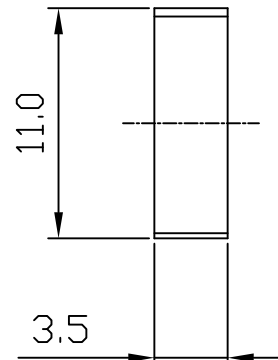
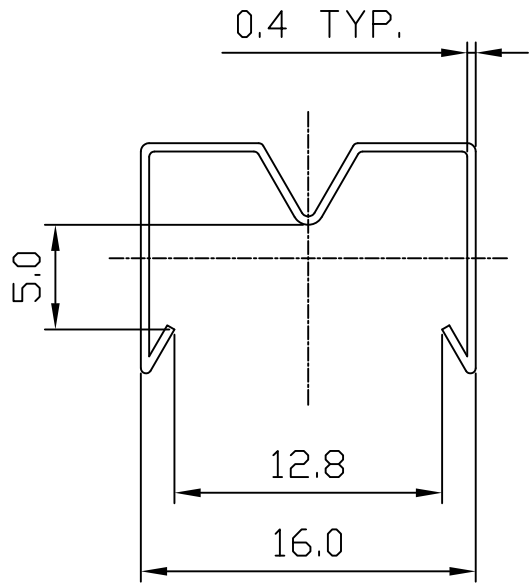
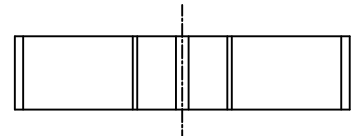

ISOMETRIC VIEW
SCALE 2:1

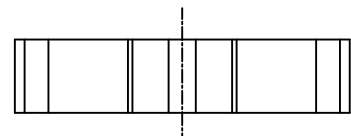

NOTES:

- THIS DRAWING CONTAINS OVERALL DIMENSIONS ONLY.
REFER TO 3D CAD DATABASE FOR COMPLETE PART INFORMATION.
- PARTS TO BE CLEAN AND FREE OF CRACKS, FOREIGN MATTER.
NO OIL OR LUBRICANTS ON THE SURFACE.
- ALL DIMENSIONS SHOWN SHALL BE CHECKED AT FIRST ARTICLE INSPECTION.
- REMOVE ALL BURRS AND SHARP EDGES.
- FINISHED PRODUCT TO BE RoHS COMPLIANT.
- TOLERANCE: ±0.50mm
- FOR STAMPED HEAT SINK: JBHAS2522

DIMENSIONAL TOLERANCE			DRAWN SIDNEY	TITLE CLIP	
DECIMAL PLACES	MILLIMETERS	INCHES		MATERIAL SUS 301	
.	-	-	CHECKED CHRIS	FINISH CLEAN	
.X	-	-		CUS. PART NO. CUS. REV.	
.XX	-	-		APPROVED CHRIS	
UNLESS OTHERWISE SPECIFIED			SCALE 2:1	PART NO.	REV.
ANGULAR DIMENSIONS ± 1.0°		THIRD ANGLE PROJECTION		JBASS0061	0
UNIT mm	SIZE A4	SHEET 1 OF 1		DATE 2023-06-08	



1

2

3

4

5

6