

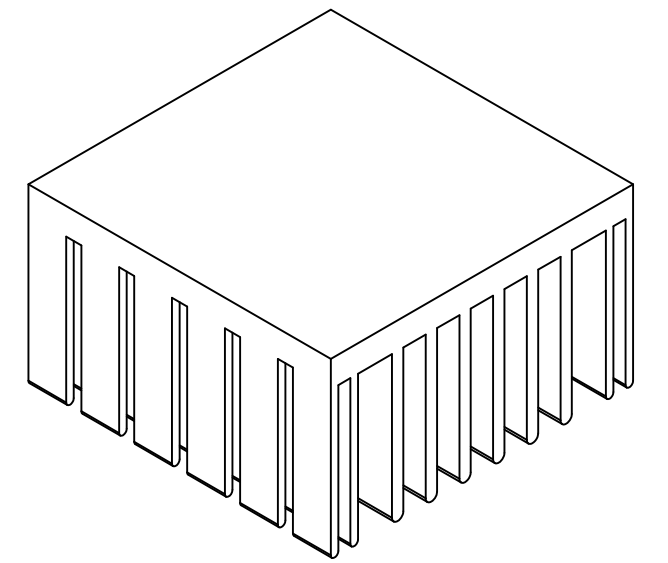

REVISIONS			
REV.	COMMENT	DATE	APPROVED
0	INITIAL RELEASE	2023-09-12	CHRIS

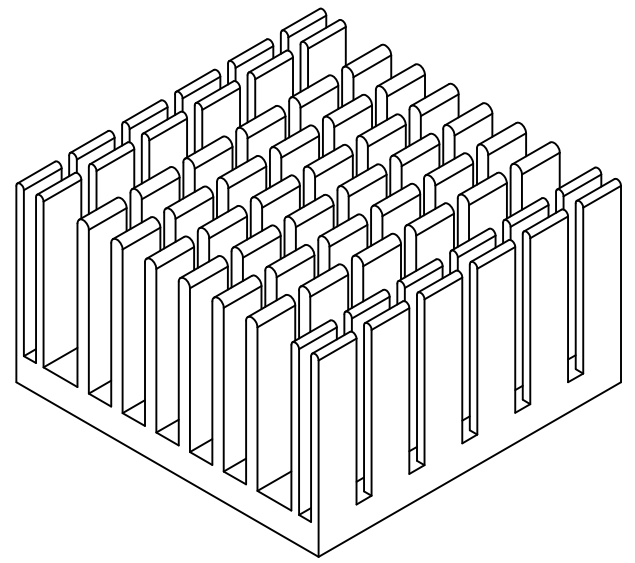

ISOMETRIC VIEW
SCALE 1:1

- NOTES:
- THIS DRAWING CONTAINS OVERALL DIMENSIONS ONLY. REFER TO 3D CAD DATABASE FOR COMPLETE PART INFORMATION.
 - PARTS TO BE CLEAN AND FREE OF CRACKS, FOREIGN MATTER. NO OIL OR LUBRICANTS ON THE SURFACE.
 - ALL DIMENSIONS SHOWN SHALL BE CHECKED AT FIRST ARTICLE INSPECTION.
 - REMOVE ALL BURRS AND SHARP EDGES.
 - FINISHED PRODUCT TO BE RoHS COMPLIANT.
 - TOLERANCE: ±0.30mm

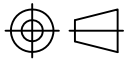
DIMENSIONAL TOLERANCE			DRAWN	TITLE				
DECIMAL PLACES	MILLIMETERS	INCHES						
.	-	-	SIDNEY	BGA HEAT SINK				
.X	-	-		MATERIAL AL 6063-T5				
.XX	-	-	CHECKED	FINISH BLACK ANODIZE				
UNLESS OTHERWISE SPECIFIED			CHRIS	CUS. PART NO.		CUS. REV.		
ANGULAR DIMENSIONS ± 1.0°		THIRD ANGLE PROJECTION 		APPROVED		PART NO. JBHAE4003		REV. 0
SCALE 1:1	UNIT mm	SIZE A4	CHRIS	SHEET 1 OF 1		DATE 2023-09-12		