

REVISIONS			
REV.	COMMENT	DATE	APPROVED
0	INITIAL RELEASE	2023-06-06	CHRIS

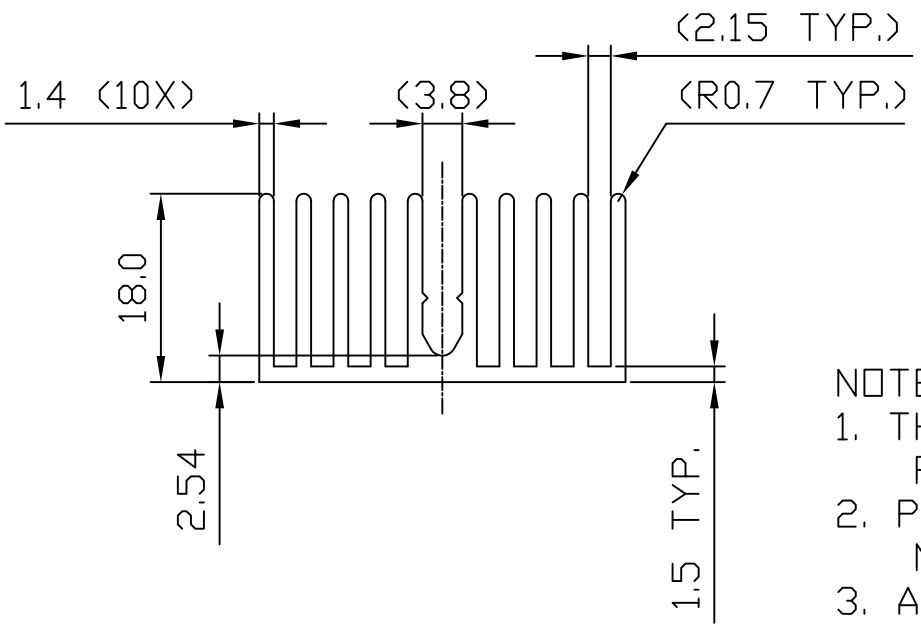

- NOTES:
1. THIS DRAWING CONTAINS OVERALL DIMENSIONS ONLY. REFER TO 3D CAD DATABASE FOR COMPLETE PART INFORMATION.
 2. PARTS TO BE CLEAN AND FREE OF CRACKS, FOREIGN MATTER. NO OIL OR LUBRICANTS ON THE SURFACE.
 3. ALL DIMENSIONS SHOWN SHALL BE CHECKED AT FIRST ARTICLE INSPECTION.
 4. REMOVE ALL BURRS AND SHARP EDGES.
 5. FINISHED PRODUCT TO BE RoHS COMPLIANT.
 6. TOLERANCE: $\pm 0.30\text{mm}$

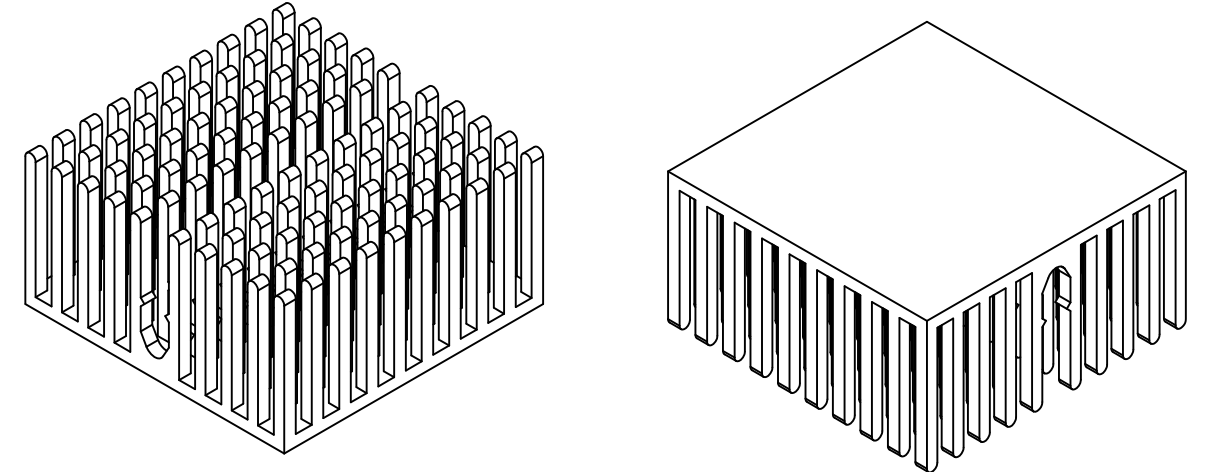
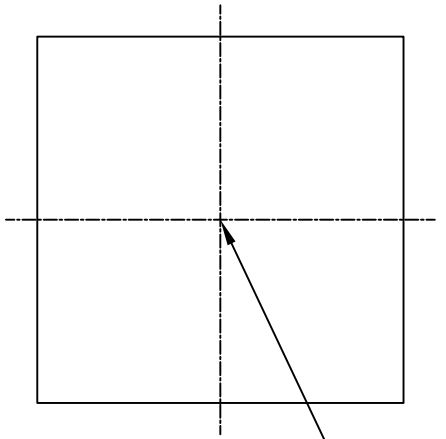

DIMENSIONAL TOLERANCE		
DECIMAL PLACES	MILLIMETERS	INCHES
.	-	-
.X	-	-
.XX	-	-
UNLESS OTHERWISE SPECIFIED		
ANGULAR DIMENSIONS	THIRD ANGLE PROJECTION	
$\pm 1.0^\circ$		
SCALE	UNIT	SIZE
1:1	mm	A4

DRAWN SIDNEY	TITLE BGA HEAT SINK	
	MATERIAL AL 6063-T5	
CHECKED CHRIS	FINISH BLACK ANODIZE	
	CUS. PART NO.	CUS. REV.
APPROVED CHRIS	PART NO.	REV.
	JBHAE3503	0



SHEET	DATE
1 OF 1	2023-06-06