

REVISIONS			
REV.	COMMENT	DATE	APPROVED
0	INITIAL RELEASE	2023-06-06	CHRIS

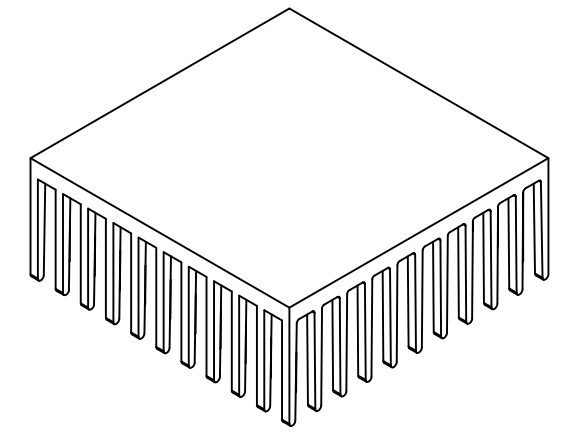

ISOMETRIC VIEW  
SCALE 1:1

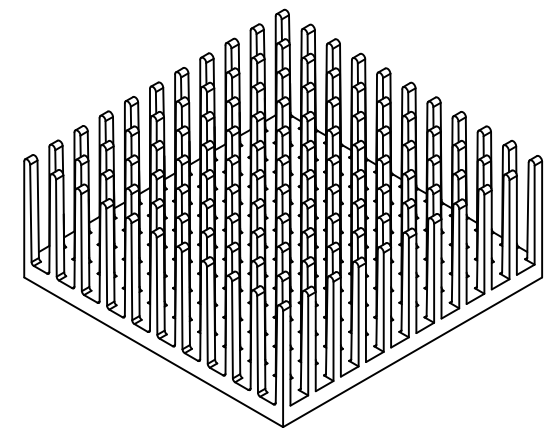
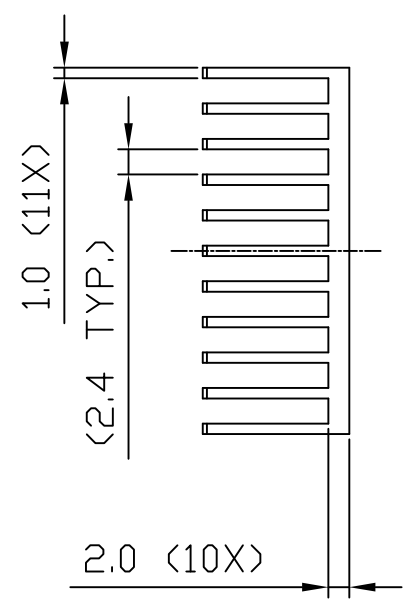
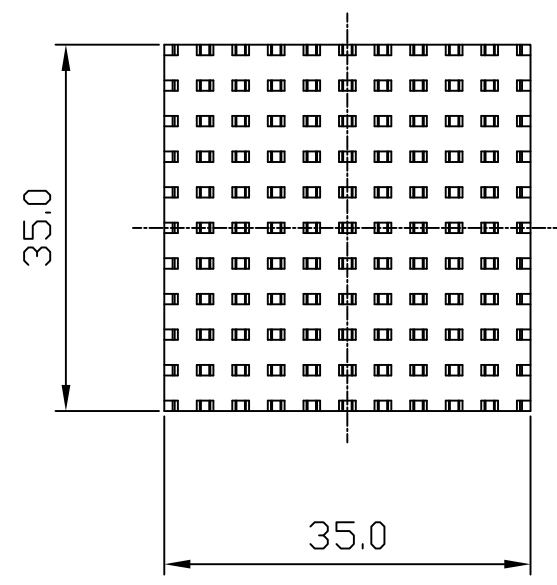
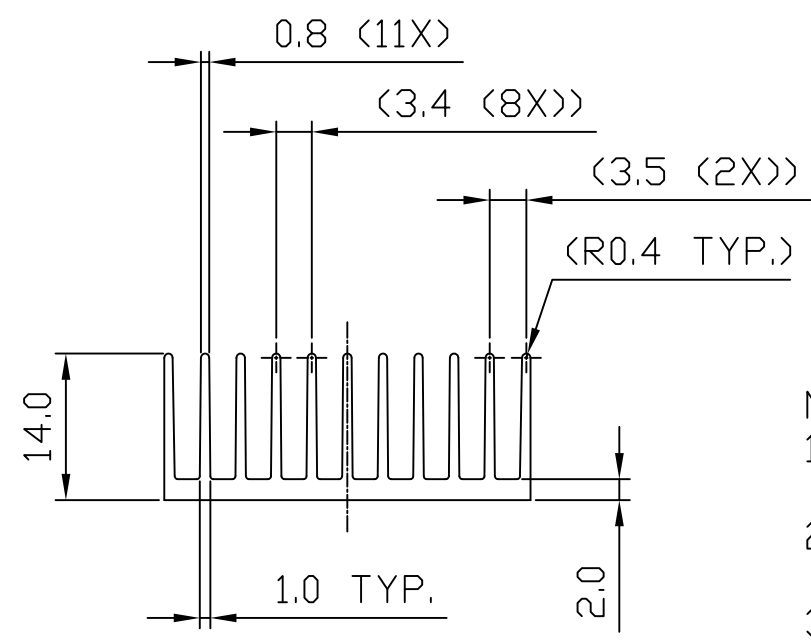

- NOTES:
- THIS DRAWING CONTAINS OVERALL DIMENSIONS ONLY. REFER TO 3D CAD DATABASE FOR COMPLETE PART INFORMATION.
  - PARTS TO BE CLEAN AND FREE OF CRACKS, FOREIGN MATTER. NO OIL OR LUBRICANTS ON THE SURFACE.
  - ALL DIMENSIONS SHOWN SHALL BE CHECKED AT FIRST ARTICLE INSPECTION.
  - REMOVE ALL BURRS AND SHARP EDGES.
  - FINISHED PRODUCT TO BE RoHS COMPLIANT.
  - TOLERANCE:  $\pm 0.30\text{mm}$

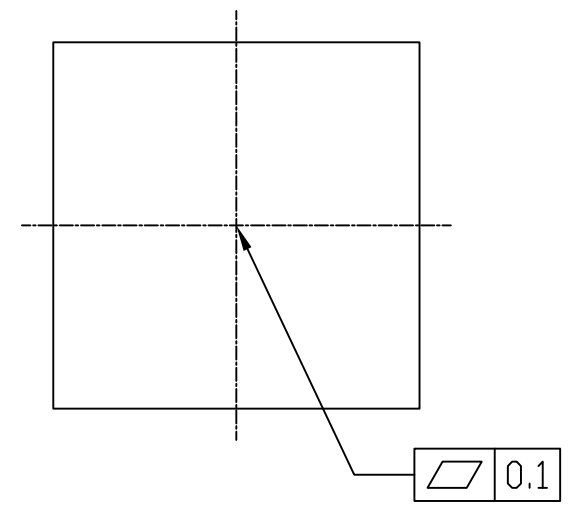

DIMENSIONAL TOLERANCE		
DECIMAL PLACES	MILLIMETERS	INCHES
.	-	-
.X	-	-
.XX	-	-
UNLESS OTHERWISE SPECIFIED		
ANGULAR DIMENSIONS	THIRD ANGLE PROJECTION	
$\pm 1.0^\circ$		
SCALE	UNIT	SIZE
1:1	mm	A4

DRAWN  
SIDNEY  
CHECKED  
CHRIS  
APPROVED  
CHRIS

TITLE  
BGA HEAT SINK  
MATERIAL  
AL 6063-T5  
FINISH  
BLACK ANODIZE  
CUS. PART NO.  
CUS. REV.  
PART NO.  
JBHAE3502  
REV.  
0



SHEET  
1 OF 1  
DATE  
2023-06-06