

1 2 3 4 5 6

REVISIONS			
REV.	COMMENT	DATE	APPROVED
0	INITIAL RELEASE	2023-03-07	CHRIS

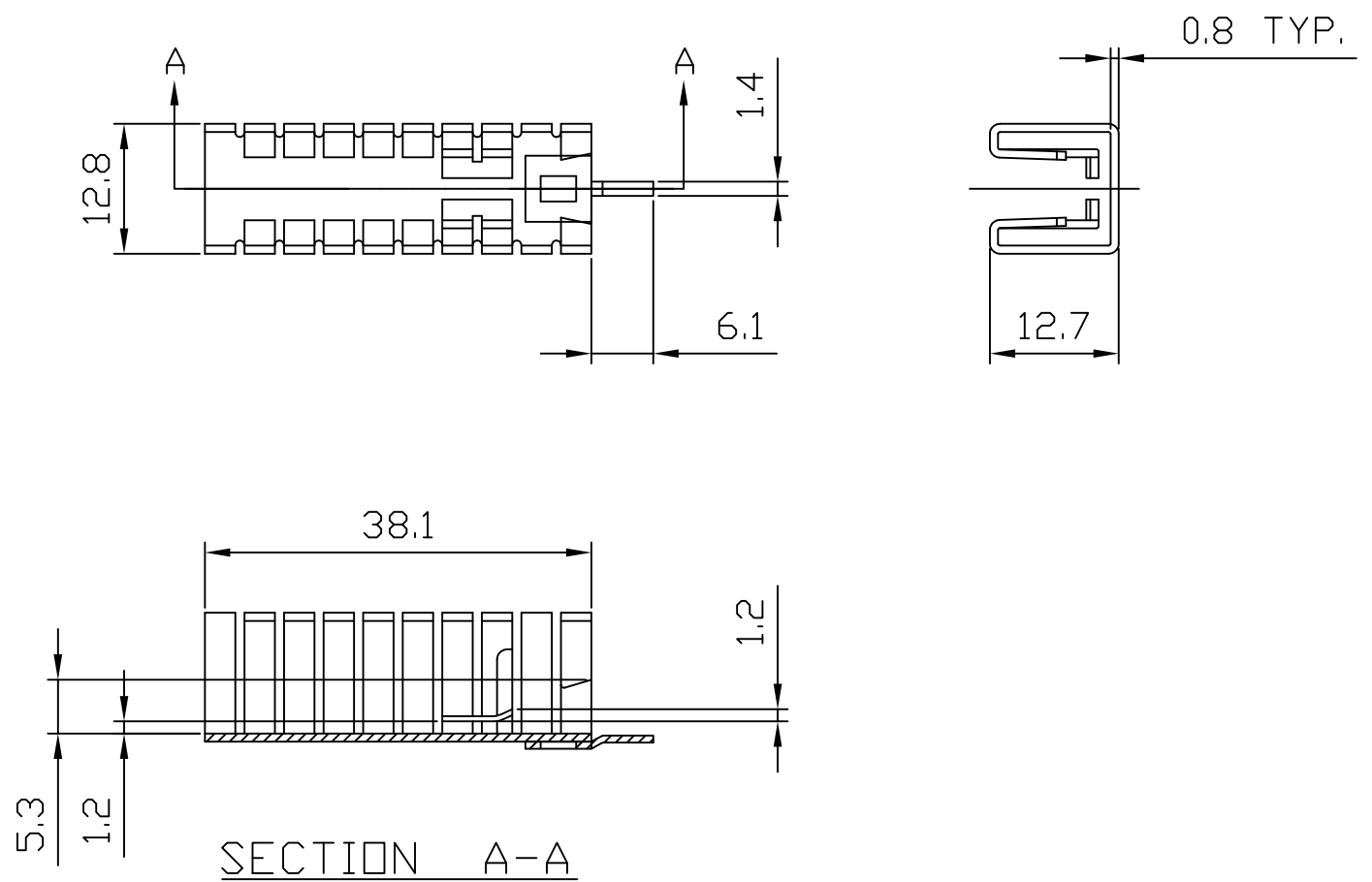

SECTION A-A

- NOTES:
1. THIS DRAWING CONTAINS OVERALL DIMENSIONS ONLY. REFER TO 3D CAD DATABASE FOR COMPLETE PART INFORMATION.
 2. PARTS TO BE CLEAN AND FREE OF CRACKS, FOREIGN MATTER. NO OIL OR LUBRICANTS ON THE SURFACE.
 3. ALL DIMENSIONS SHOWN SHALL BE CHECKED AT FIRST ARTICLE INSPECTION.
 4. REMOVE ALL BURRS AND SHARP EDGES.
 5. FINISHED PRODUCT TO BE RoHS COMPLIANT.
 6. TOLERANCE: $\pm 0.50\text{mm}$

DIMENSIONAL TOLERANCE			DRAWN SIDNEY	TITLE STAMPED HEAT SINK		
DECIMAL PLACES	MILLIMETERS	INCHES		CHECKED CHRIS	MATERIAL AL 5052	
.	-	-			FINISH BLACK ANODIZE	
.X	-	-			CUS. PART NO.	
.XX	-	-	APPROVED CHRIS	CUS. REV.		
UNLESS OTHERWISE SPECIFIED				PART NO. JBHAS0041		
ANGULAR DIMENSIONS	THIRD ANGLE PROJECTION		SCALE 1:1	REV. 0	SHEET 1 OF 1	
$\pm 1.0^\circ$	UNIT mm	SIZE A4		DATE 2023-03-07		



1 2 3 4 5 6